

PFNA (Finite Element Method) Result

Contents

PFNA (location 1: 0.5 cm below LT)	3
Force: 125 N.....	3
Force: 250 N.....	4
Force: 375 N.....	5
Force: 500 N.....	6
PFNA (location 2: 1 cm below LT)	8
Force: 125 N.....	8
Force: 250 N.....	9
Force: 375 N.....	10
Force: 500 N.....	11
PFNA (location 3: 1.5 cm below LT)	13
Force: 125 N.....	13
Force: 250 N.....	14
Force: 375 N.....	15
Force: 500 N.....	16
PFNA (location 4: 2 cm below LT)	18
Force: 125 N.....	18
Force: 250 N.....	19
Force: 375 N.....	20
Force: 500 N.....	21
PFNA (location 5: 2.5 cm below LT)	23
Force: 125 N.....	23
Force: 250 N.....	24
Force: 375 N.....	25
Force: 500 N.....	26
PFNA (location 6: 3 cm below LT)	28
Force: 125 N.....	28
Force: 250 N.....	29
Force: 375 N.....	30

Force: 500 N.....	31
PFNA (location 7: 3.5 cm below LT).....	33
Force: 125 N.....	33
Force: 250 N.....	34
Force: 375 N.....	35
Force: 500 N.....	36
PFNA (location 8: 4 cm below LT).....	38
Force: 125 N.....	38
Force: 250 N.....	39
Force: 375 N.....	40
Force: 500 N.....	41
PFNA (location 9: 4.5 cm below LT).....	43
Force: 125 N.....	43
Force: 250 N.....	44
Force: 375 N.....	45
Force: 500 N.....	46

PFNA (location 1: 0.5 cm below LT)

Force: 125 N

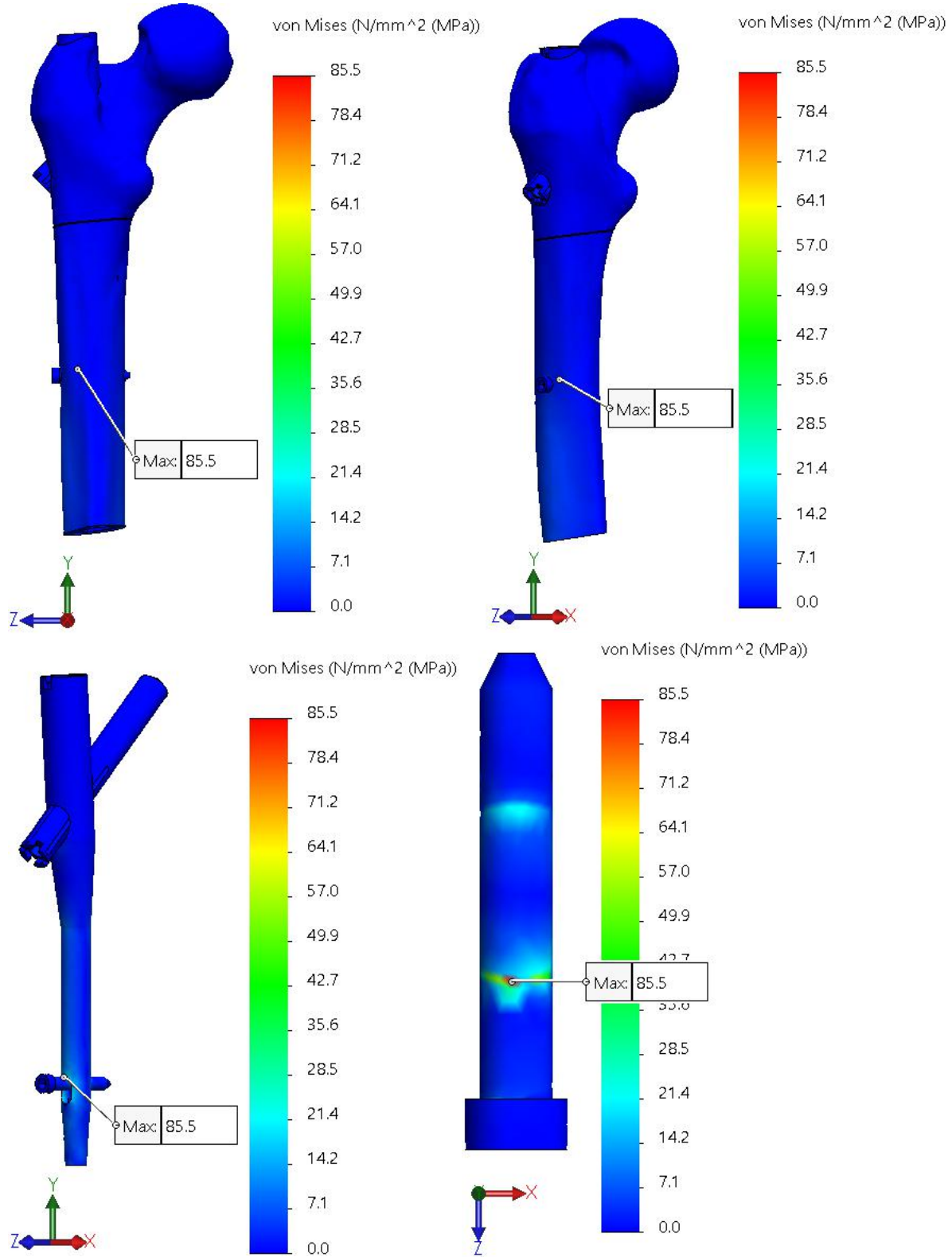

Force: 250 N

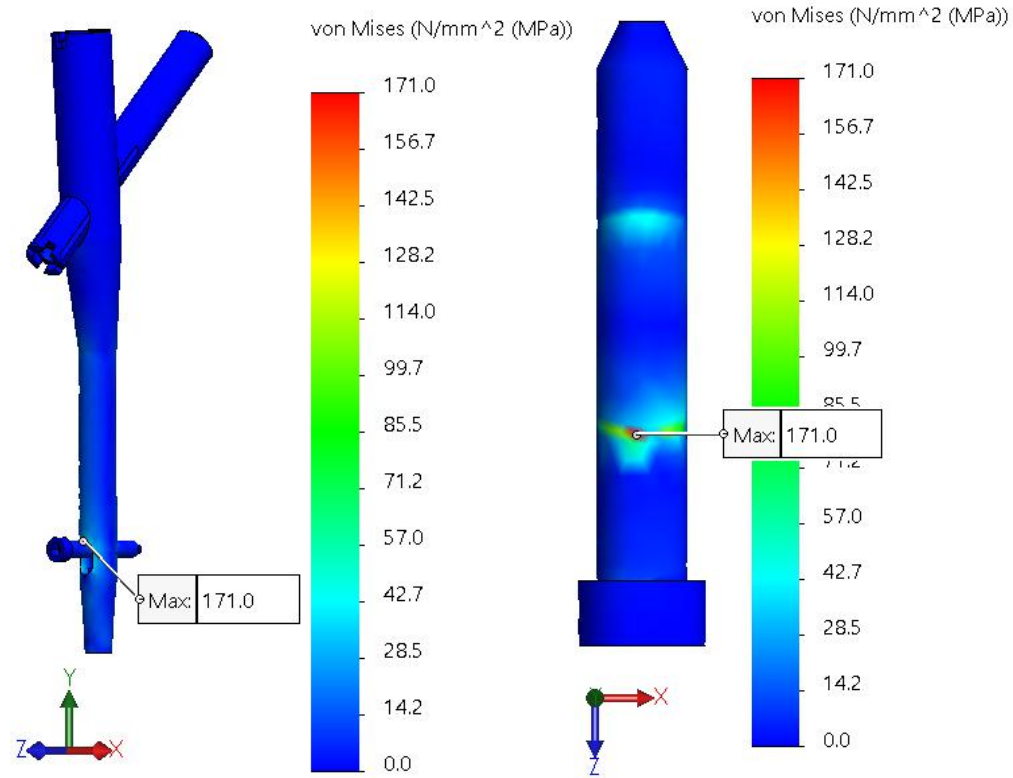
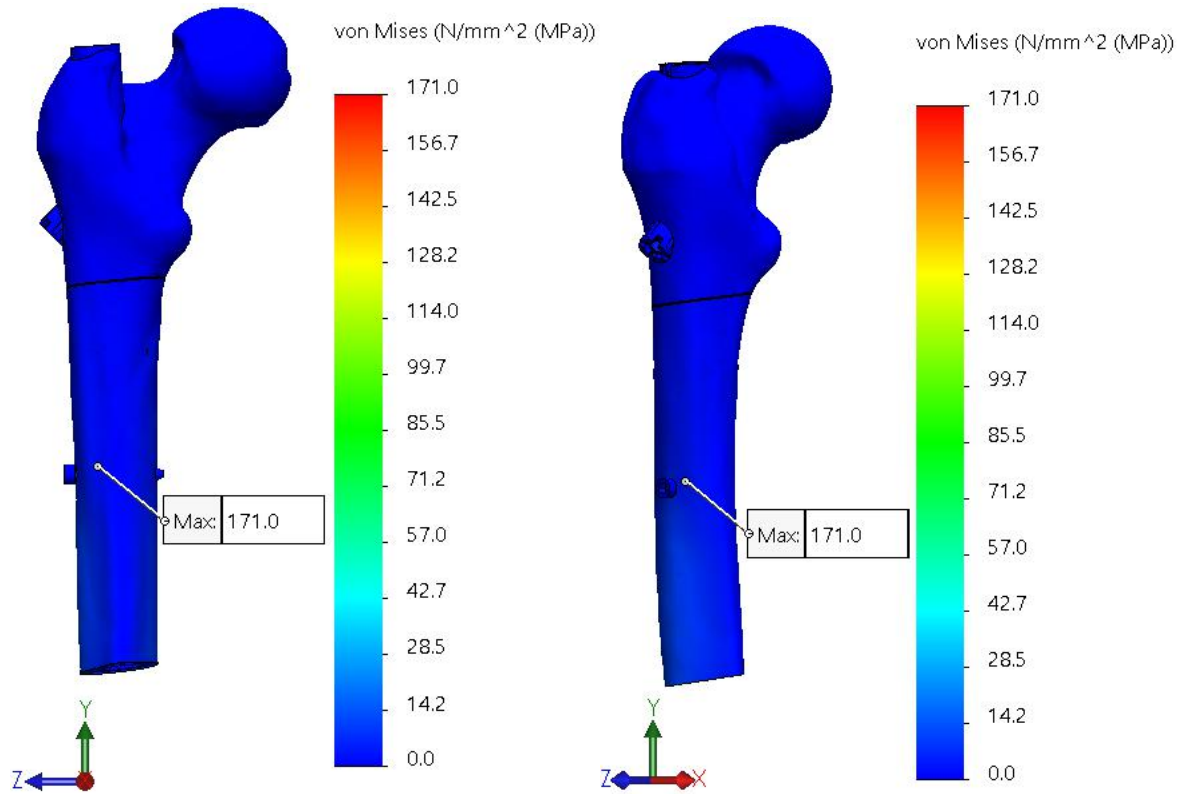

Force: 375 N

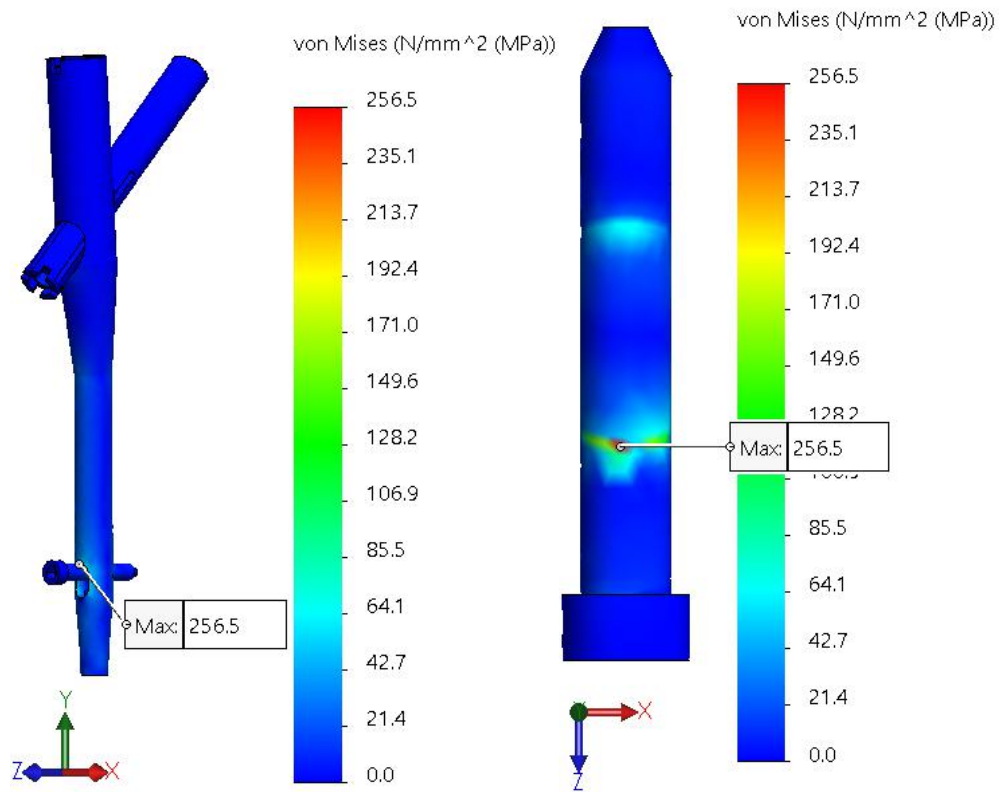
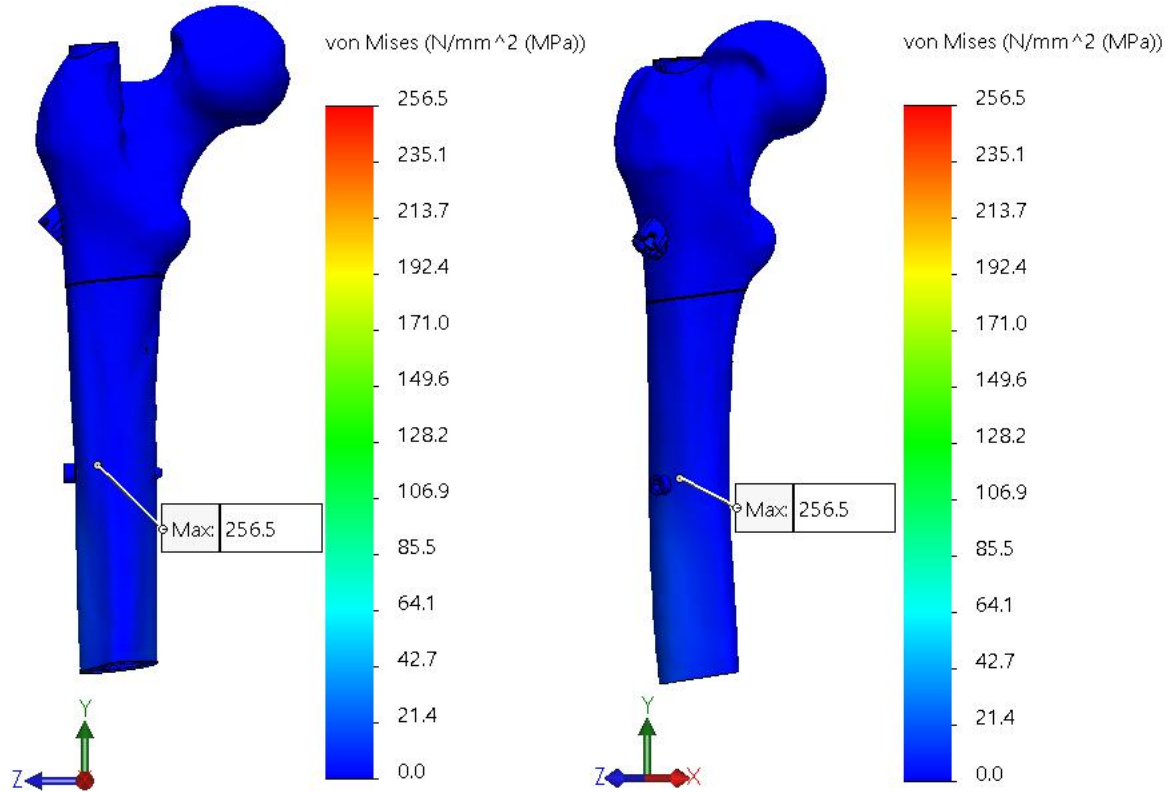

Force: 500 N

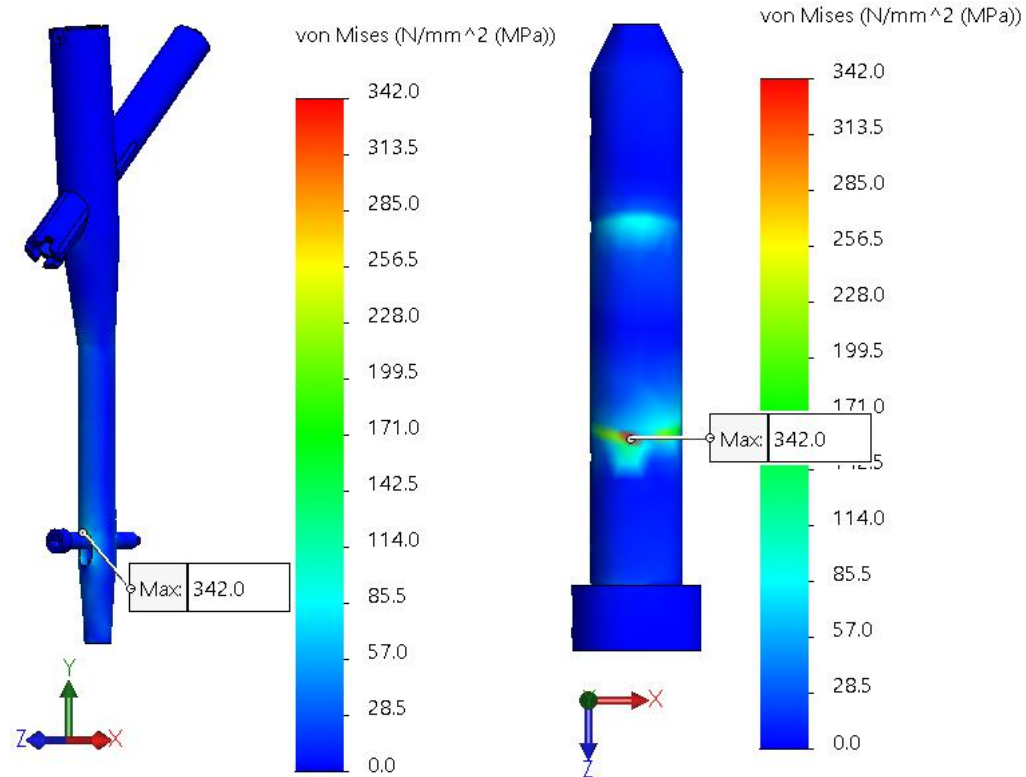
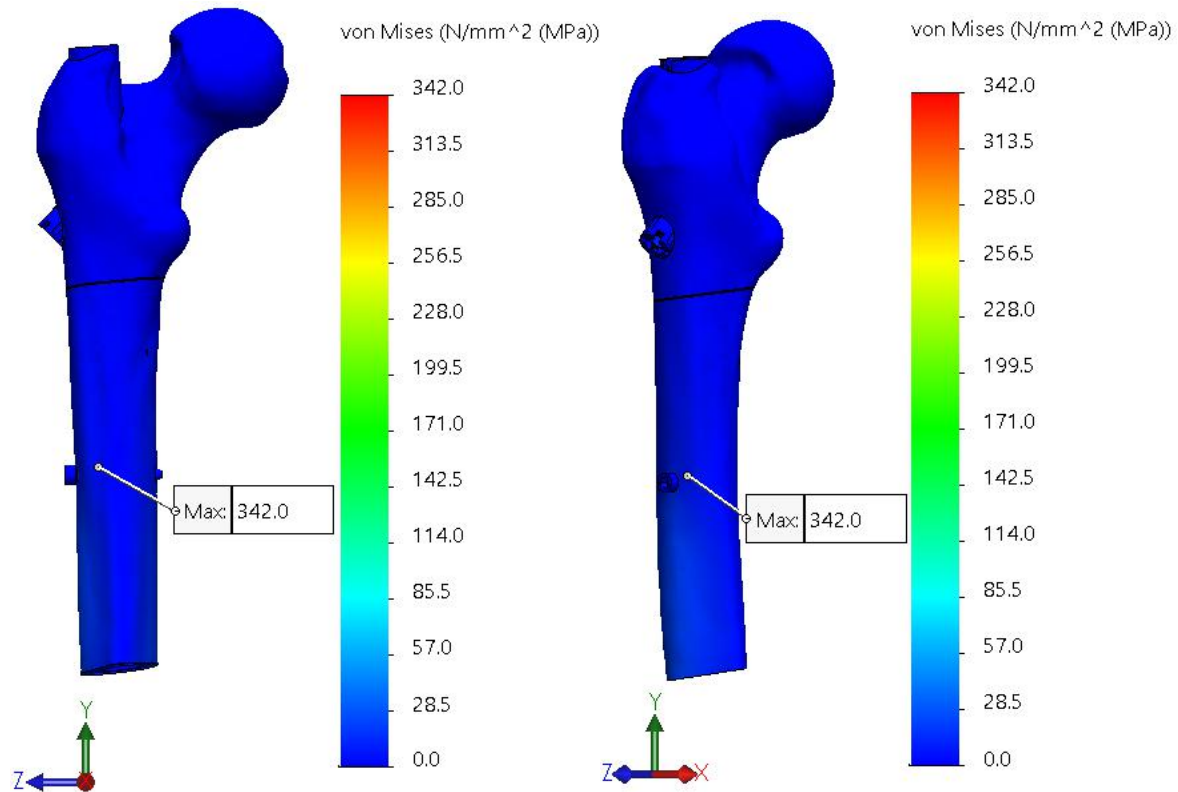

von Mises (N/mm² (MPa))

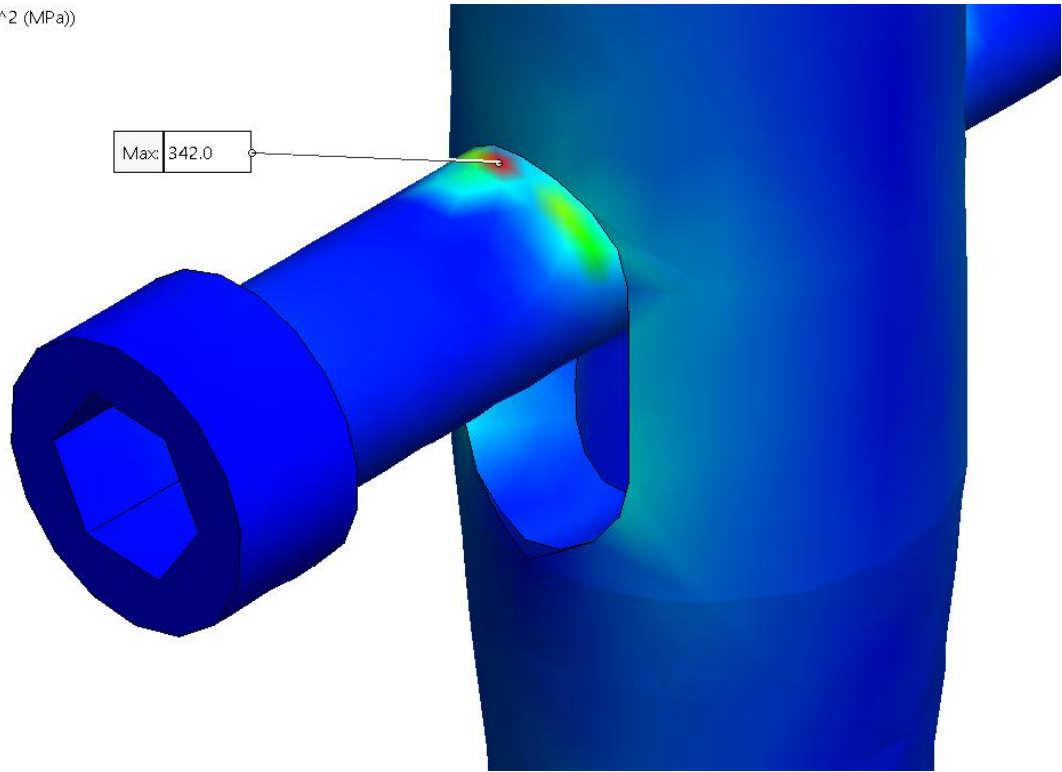
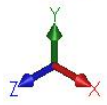
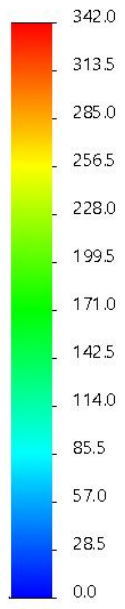

PFNA (location 2: 1 cm below LT)

Force: 125 N

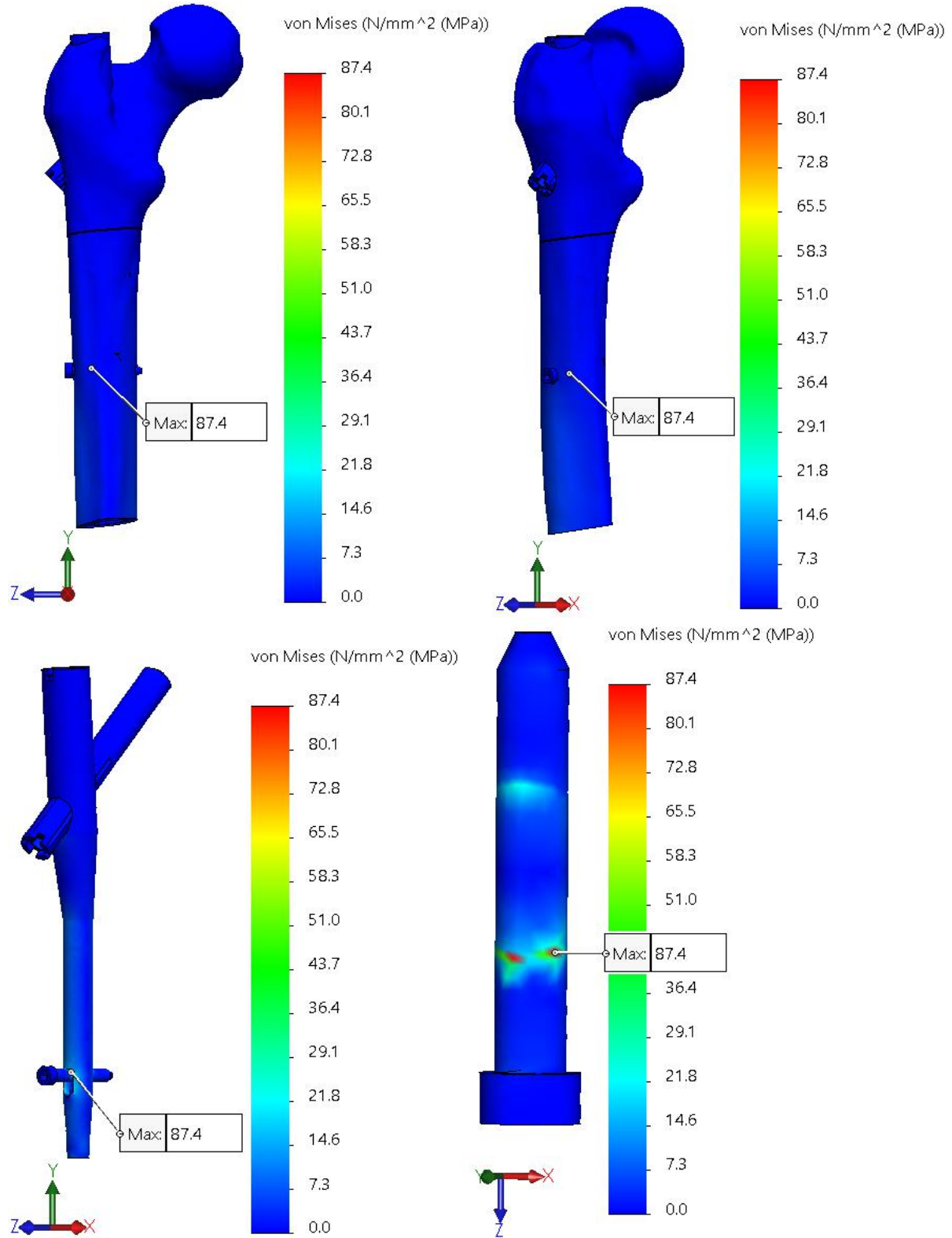

Force: 250 N

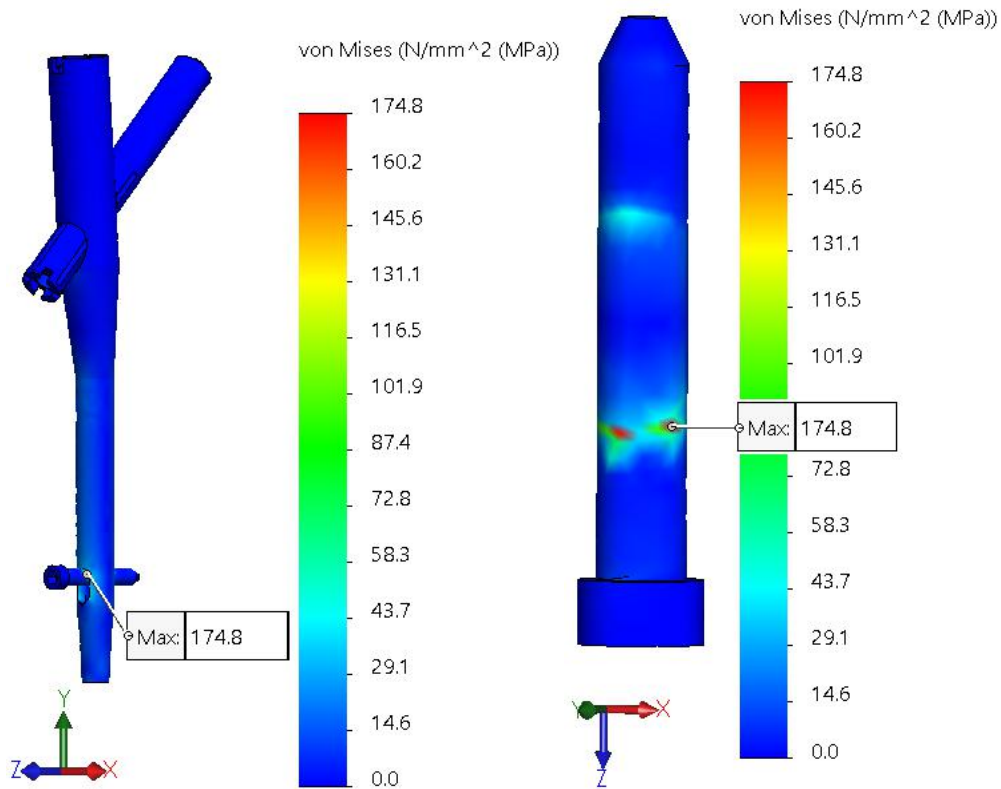
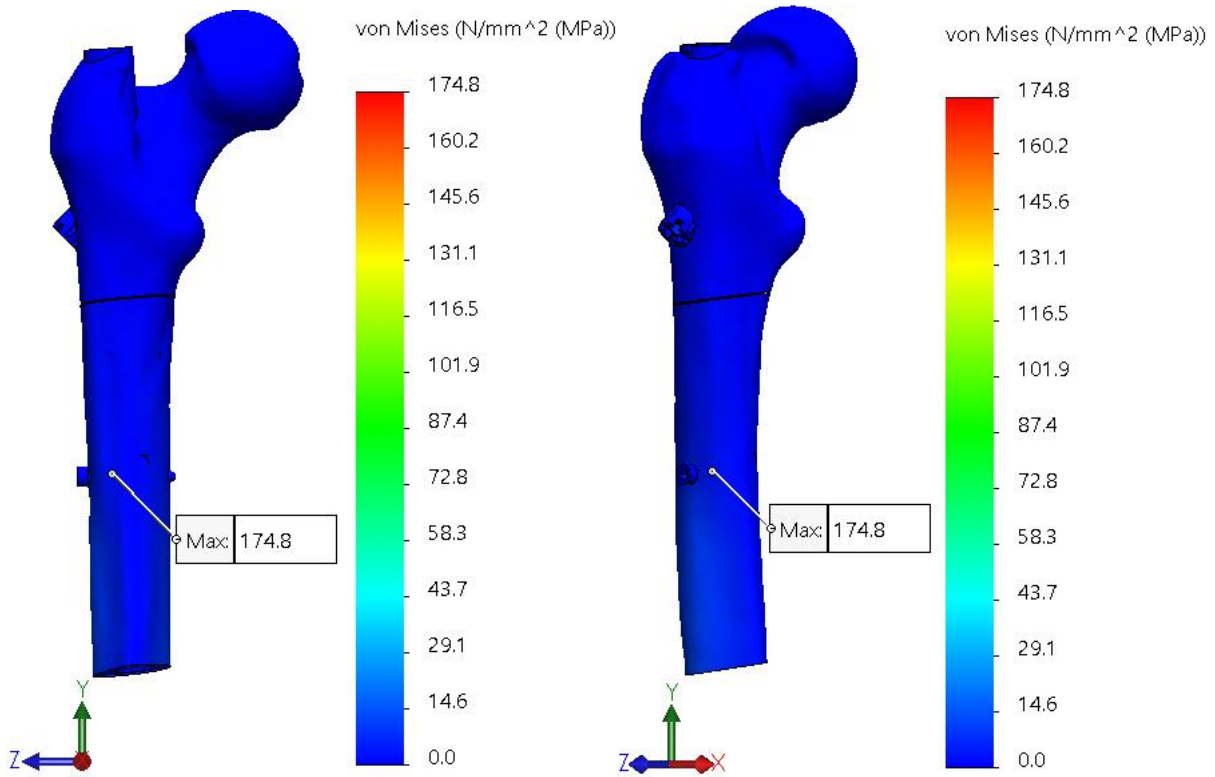

Force: 375 N

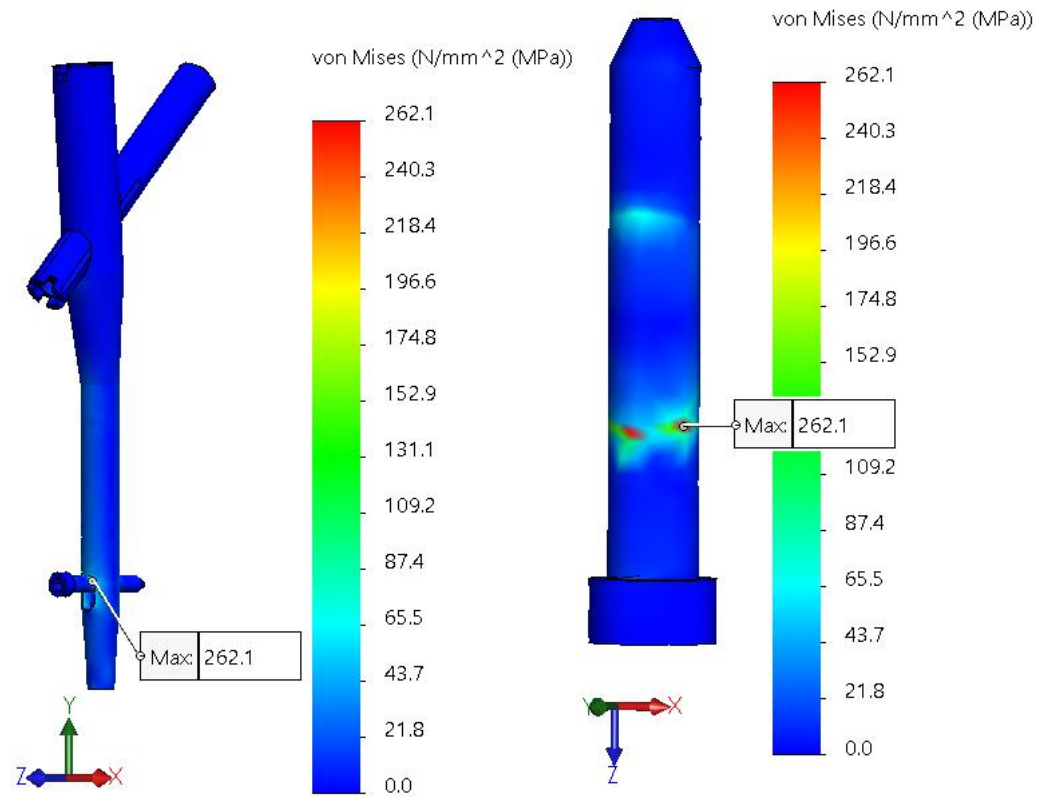
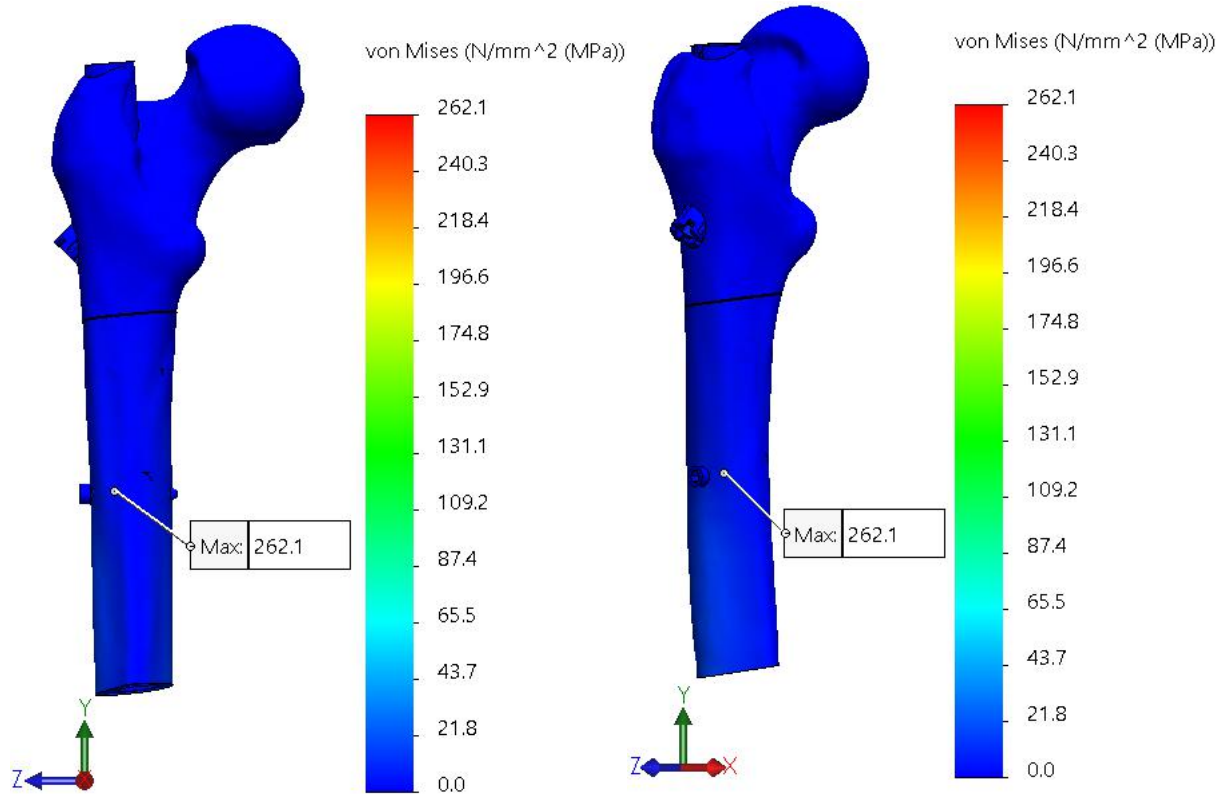

Force: 500 N

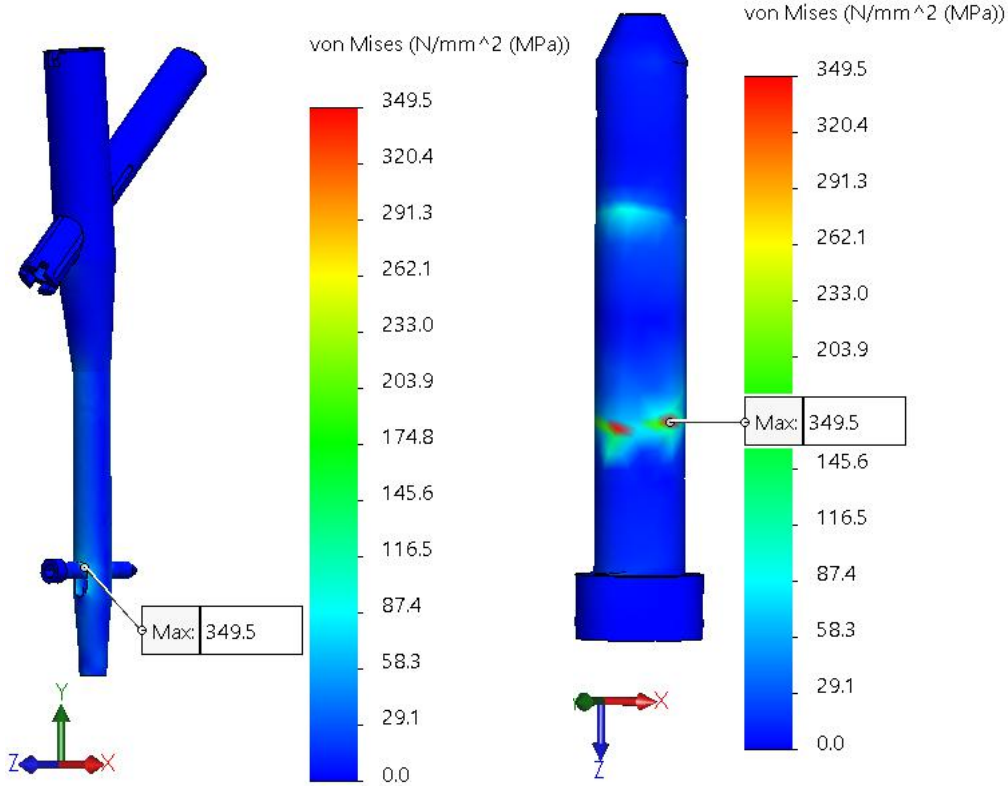
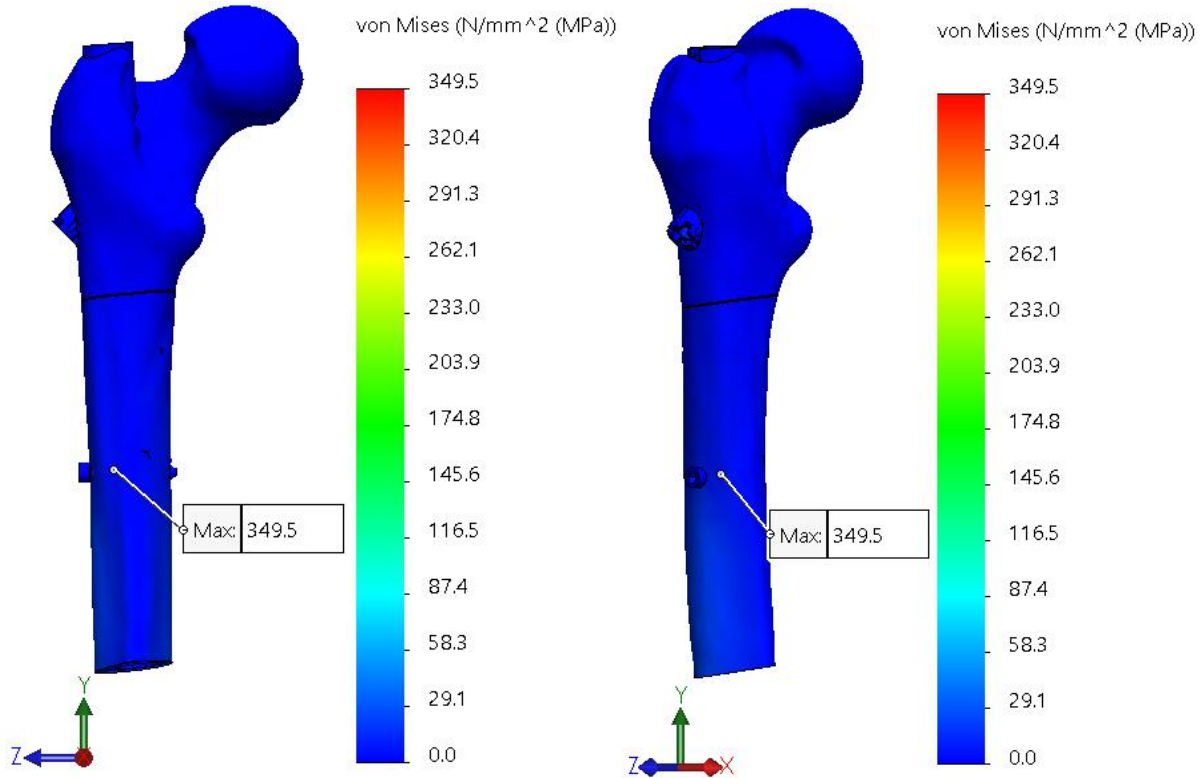

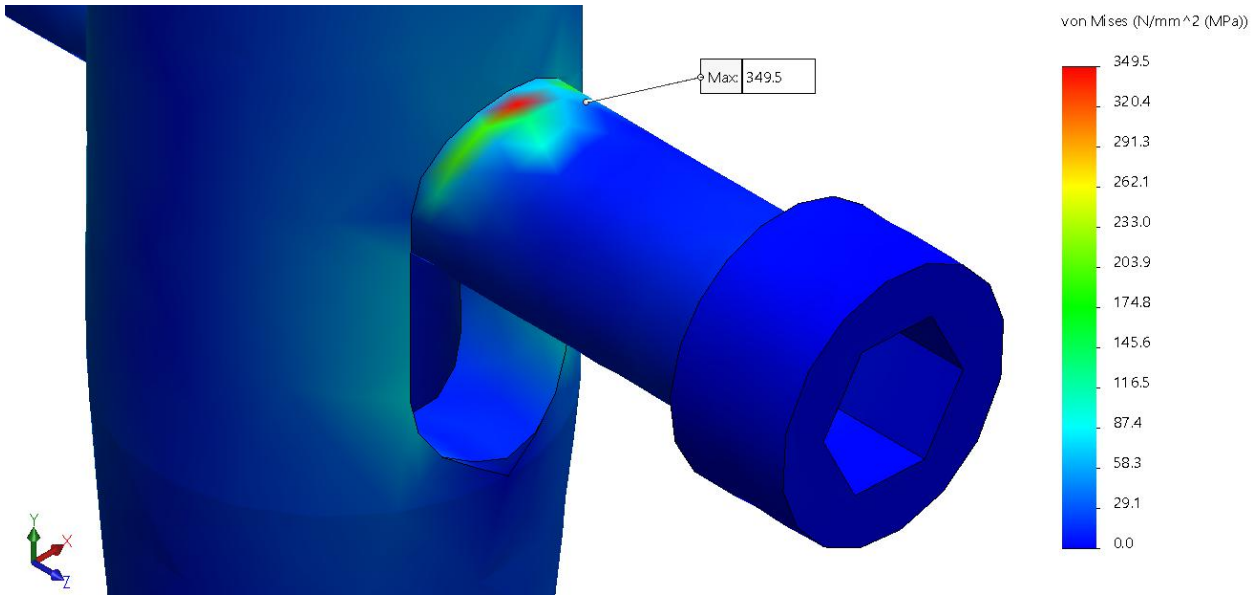
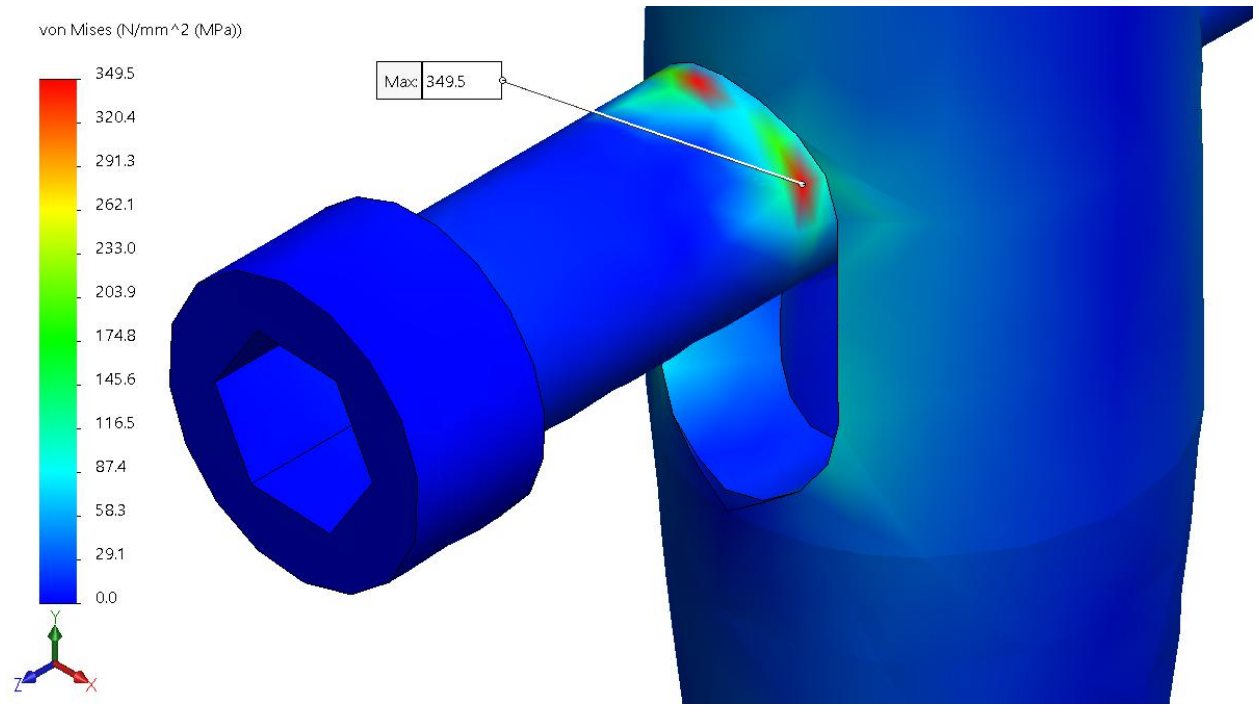

PFNA (location 3: 1.5 cm below LT)

Force: 125 N

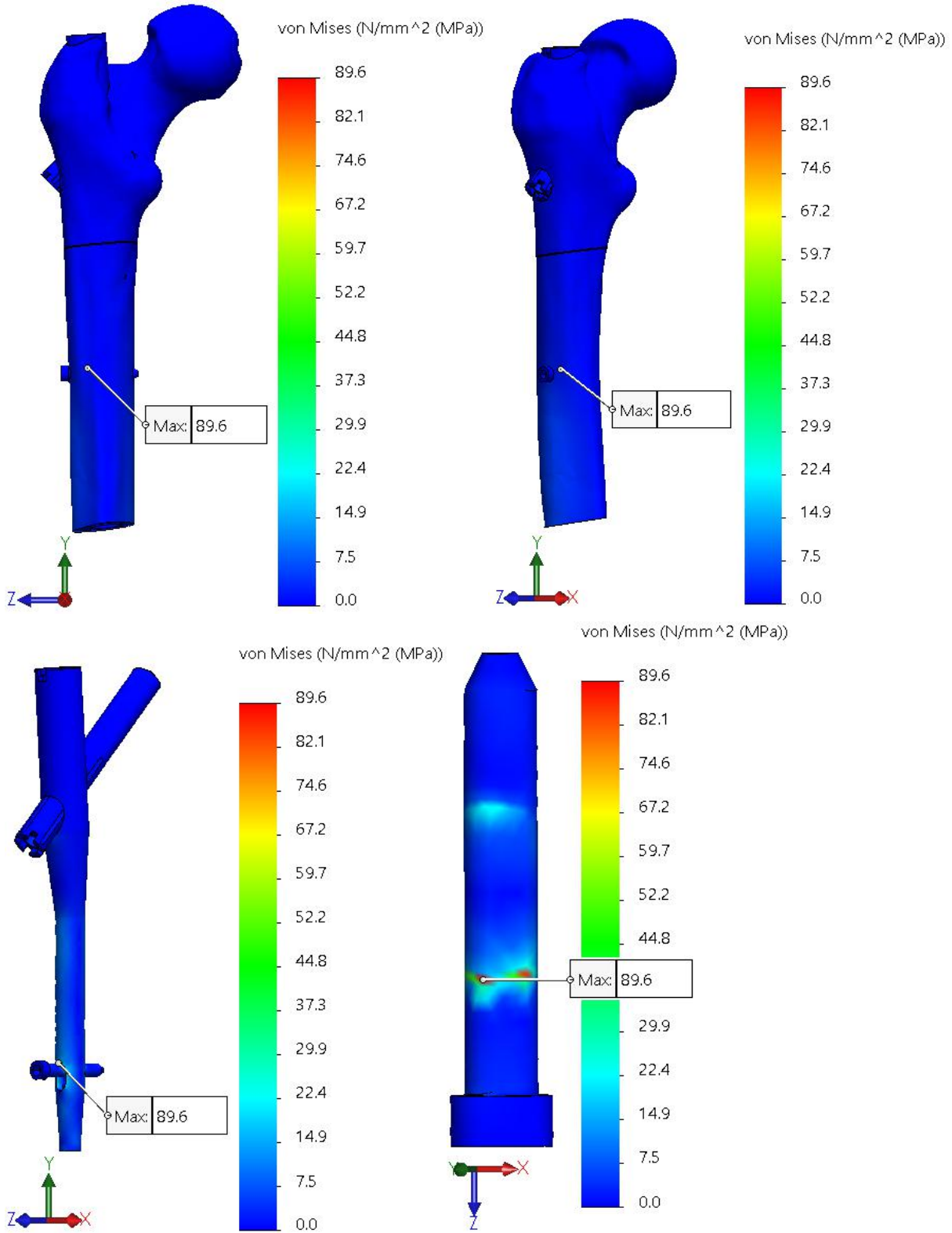

Force: 250 N

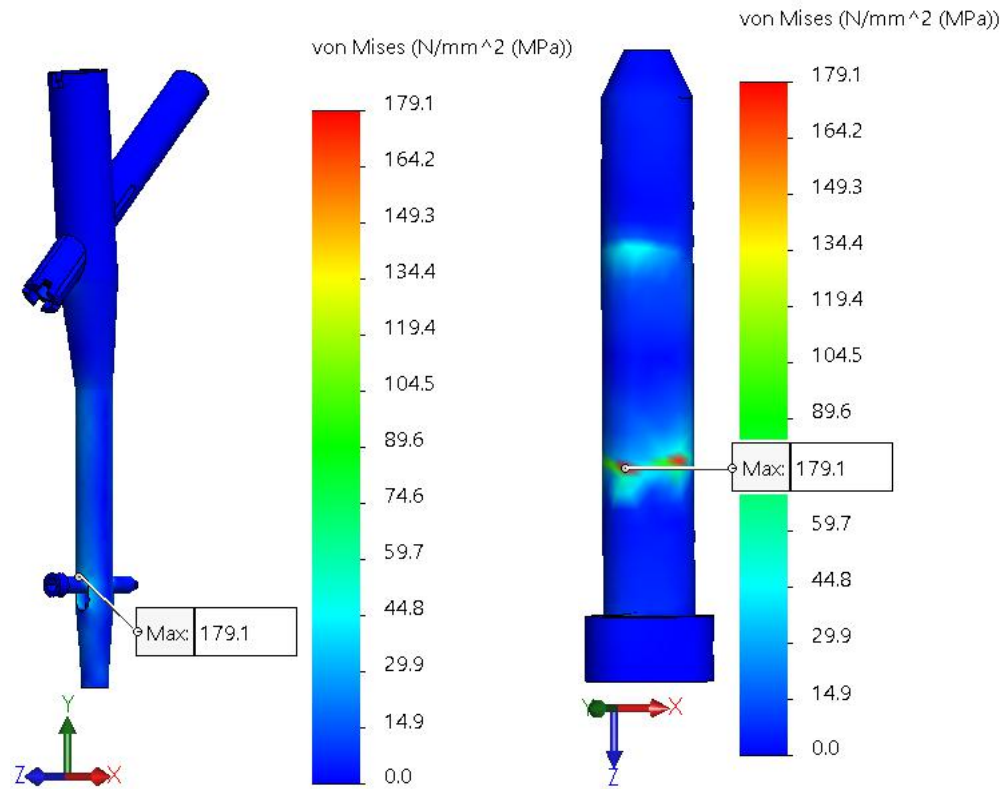
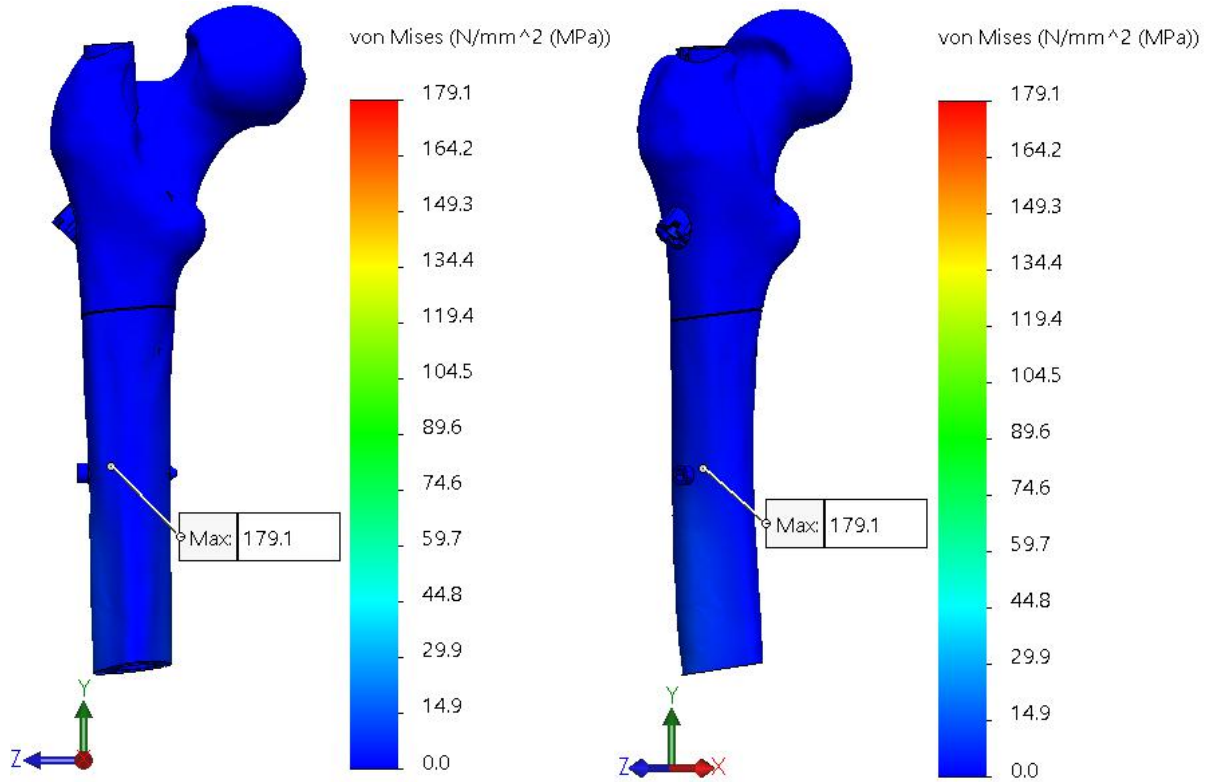

Force: 375 N

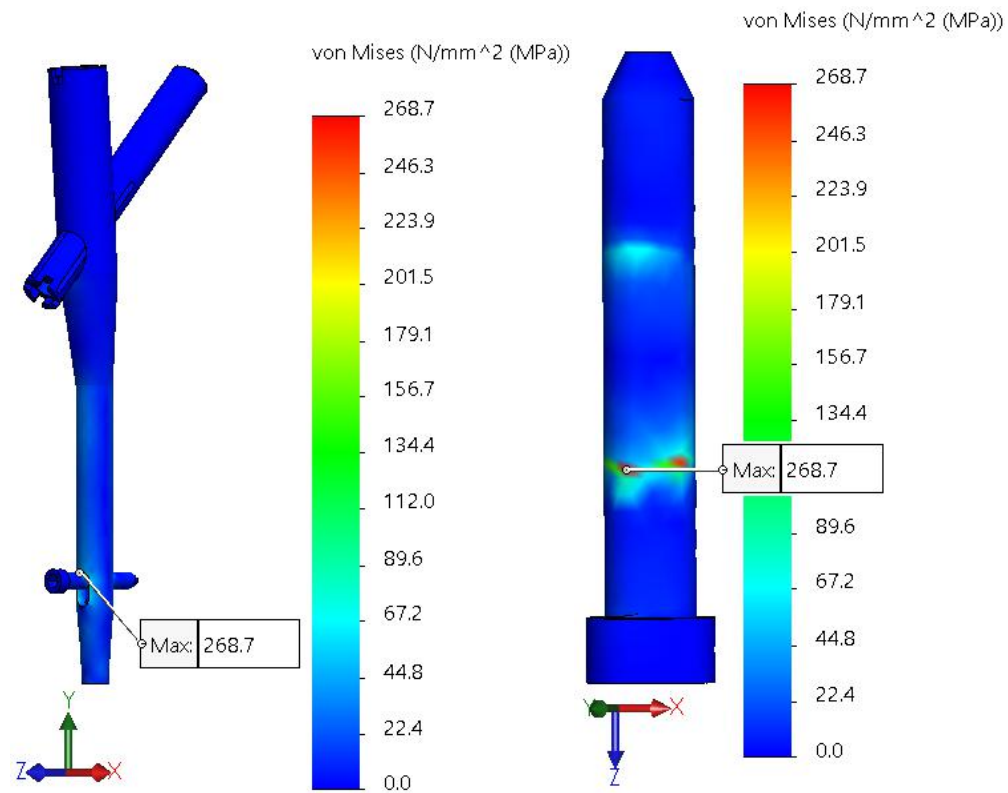
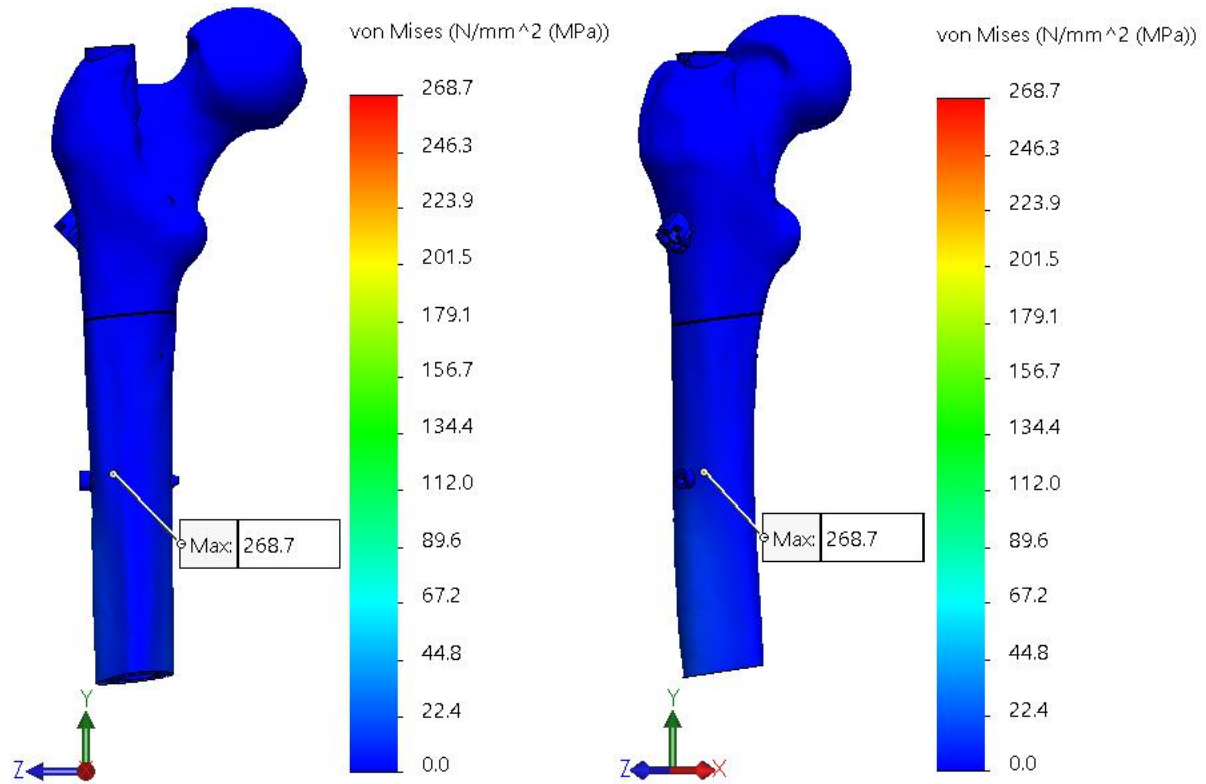

Force: 500 N

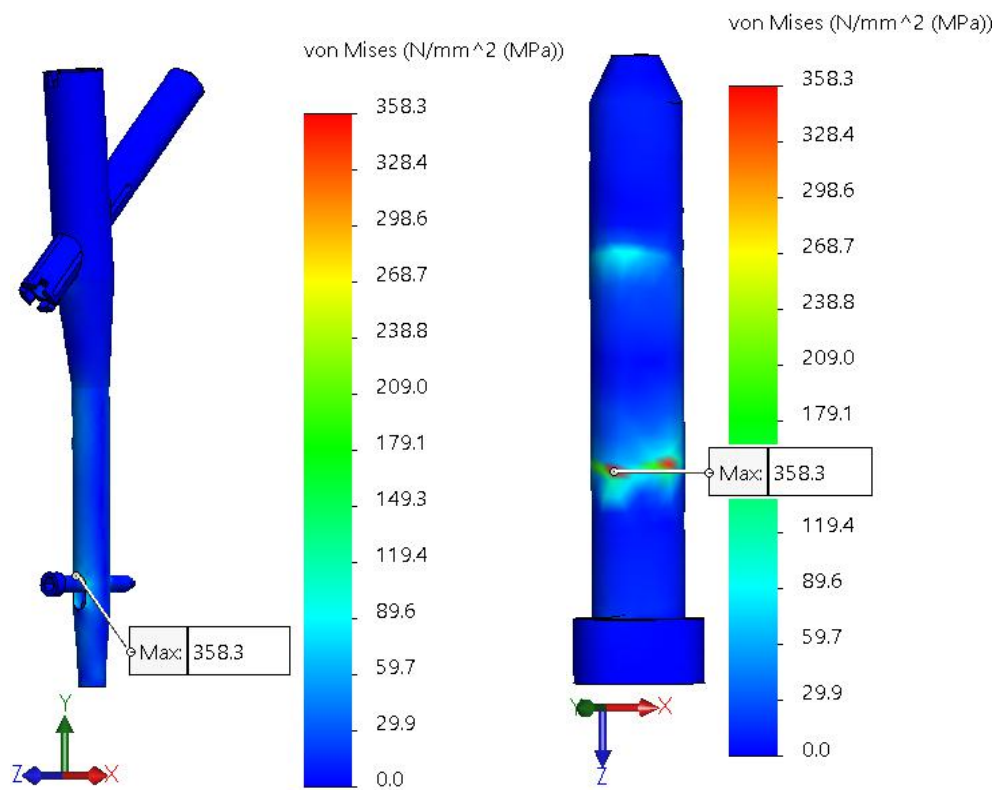
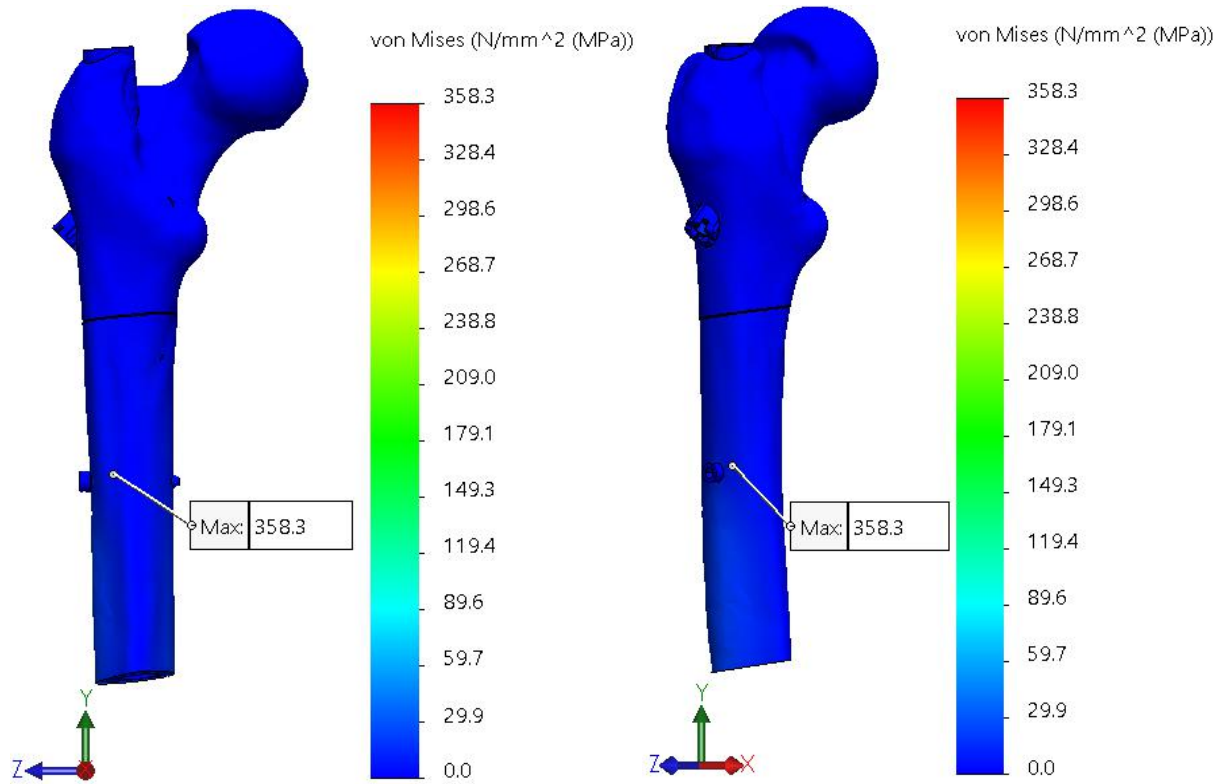

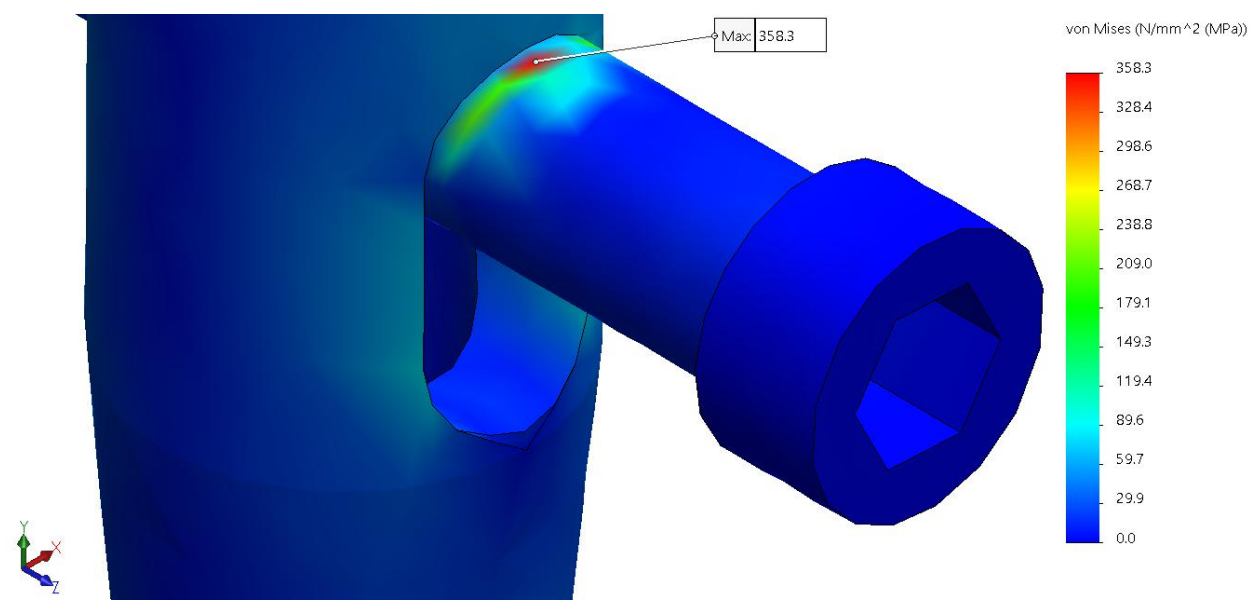
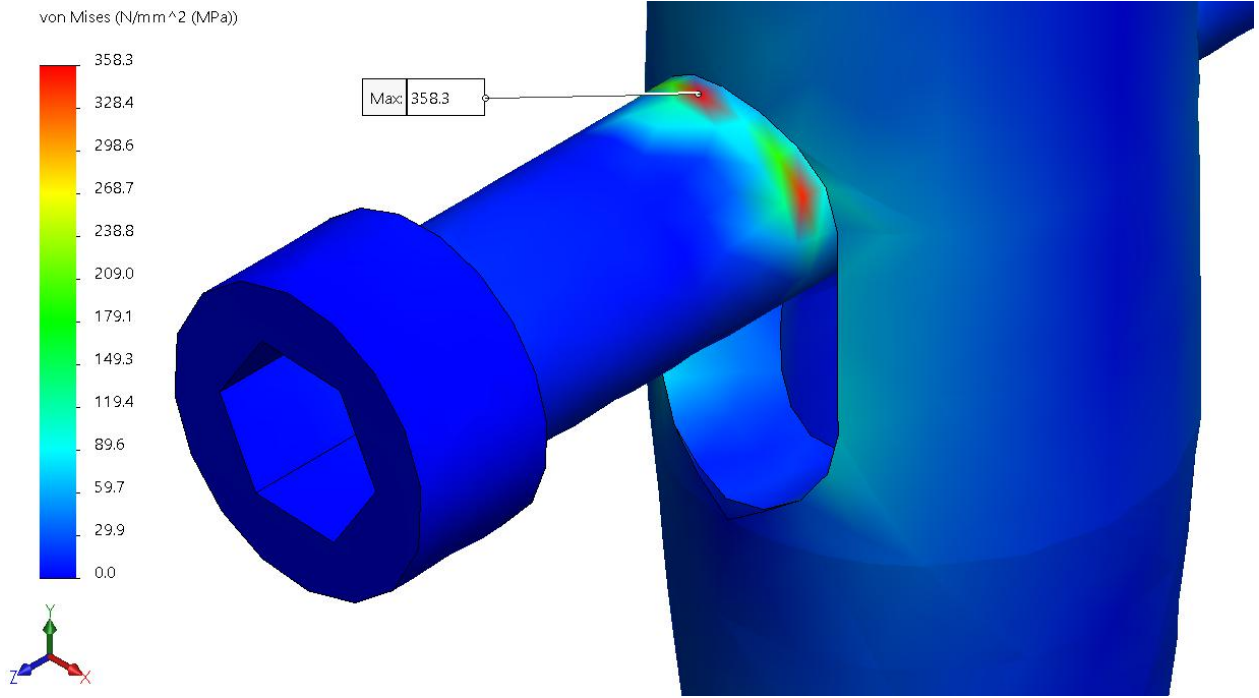

PFNA (location 4: 2 cm below LT)

Force: 125 N

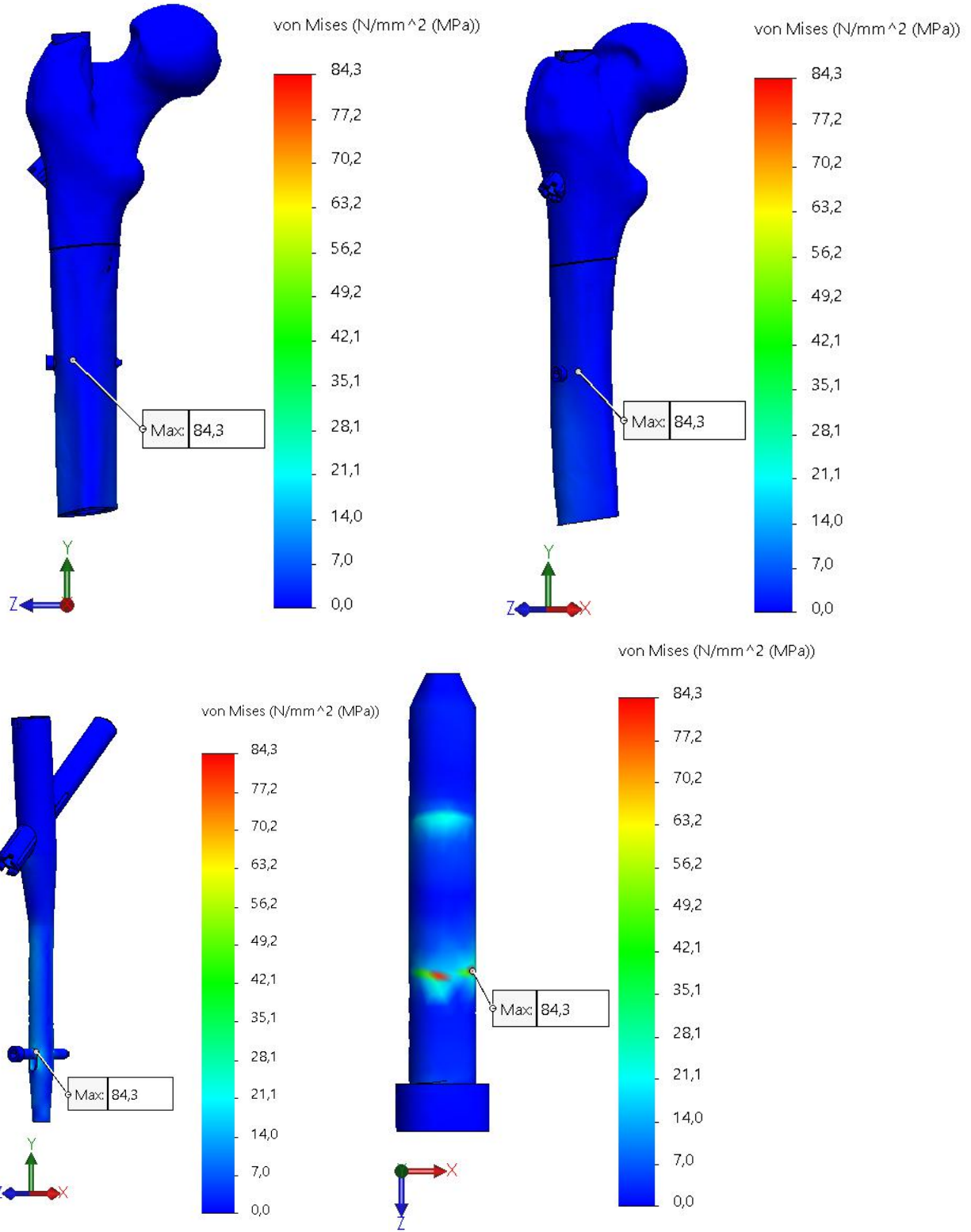

Force: 250 N

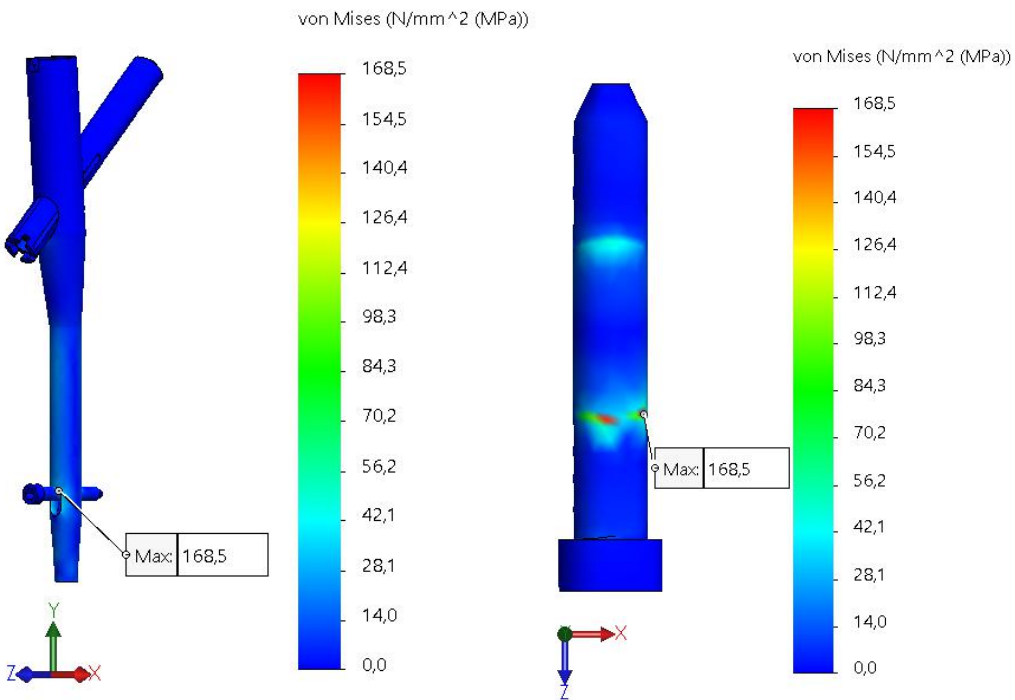
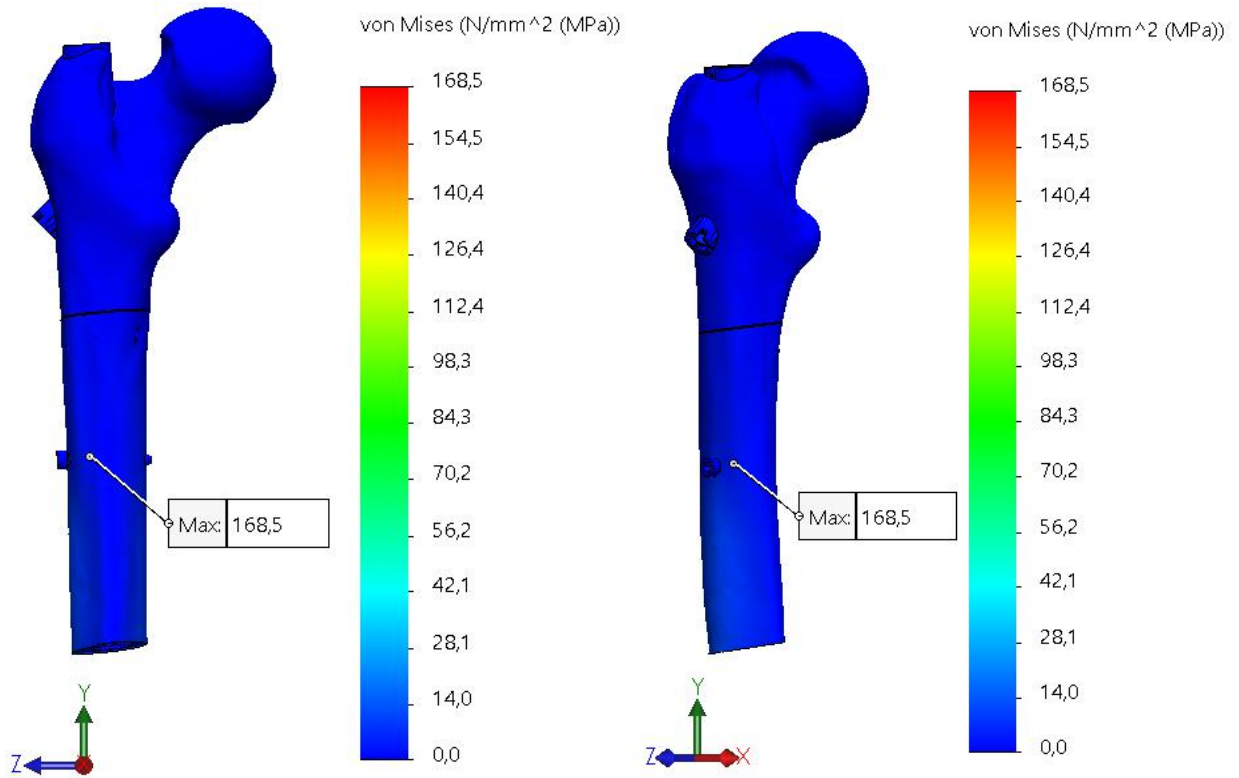

Force: 375 N

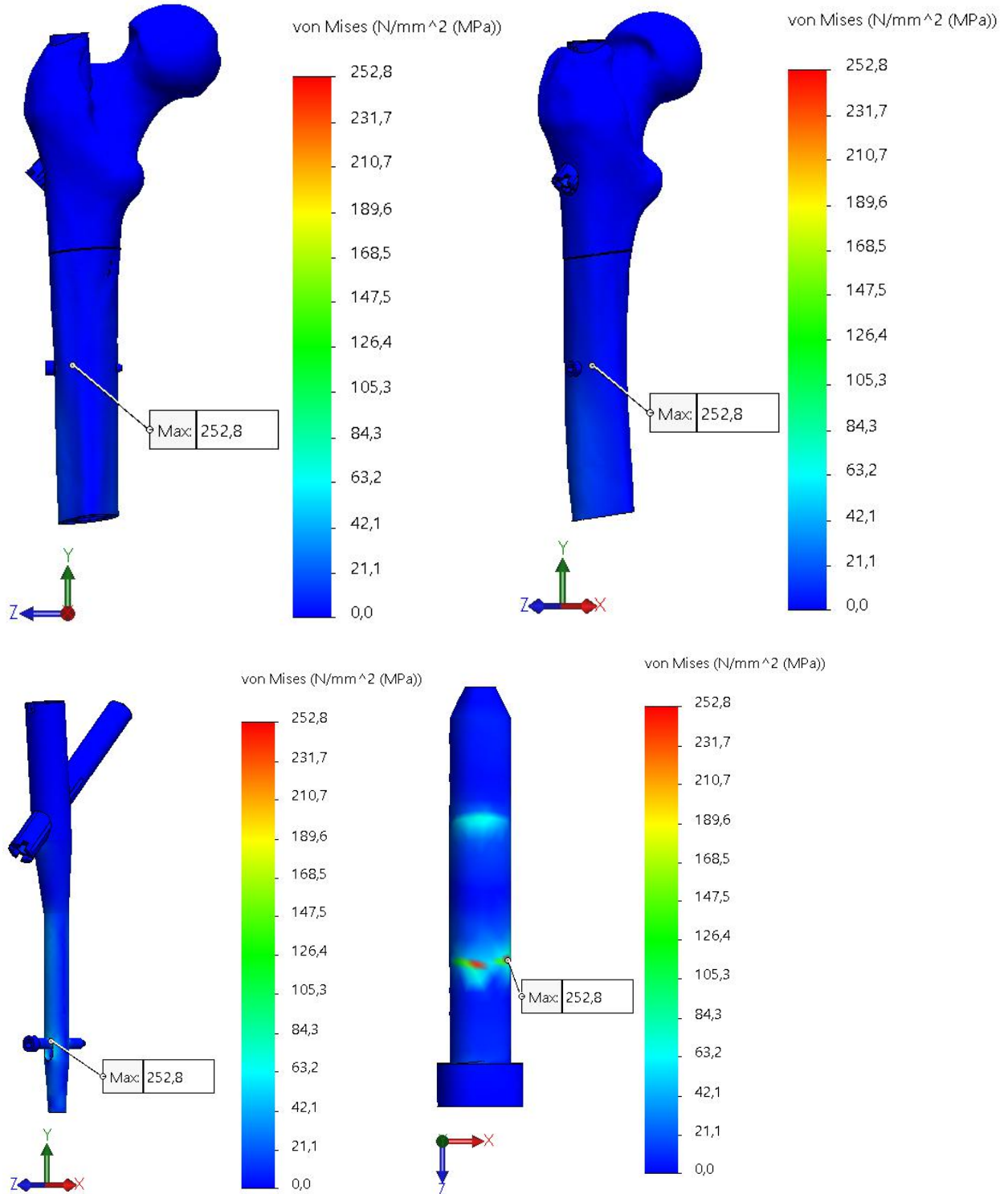

Force: 500 N

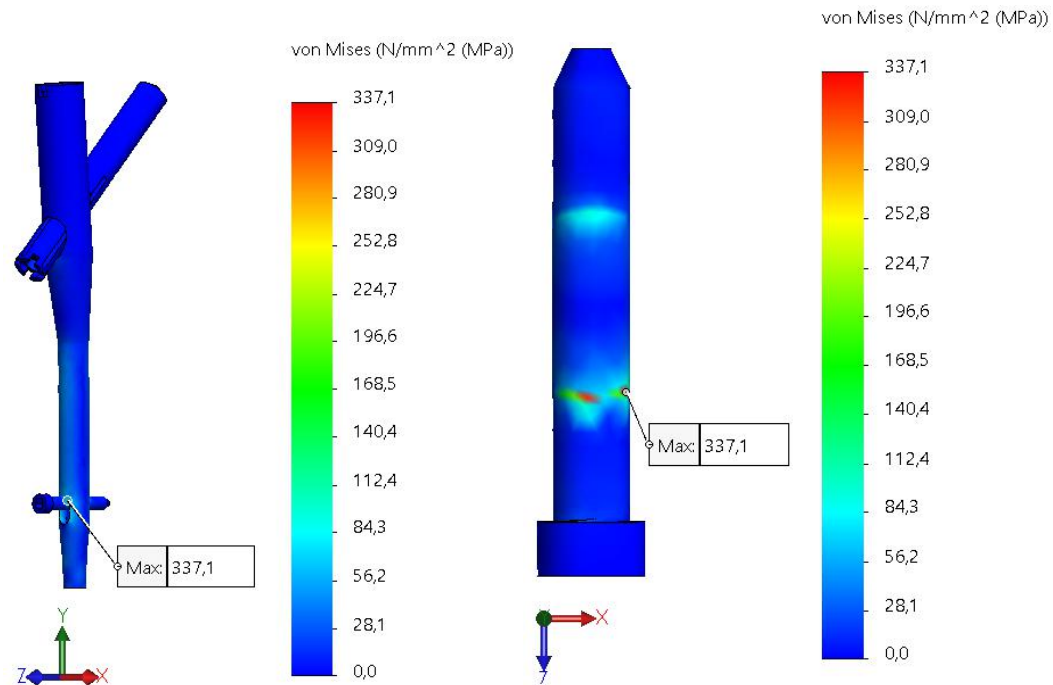
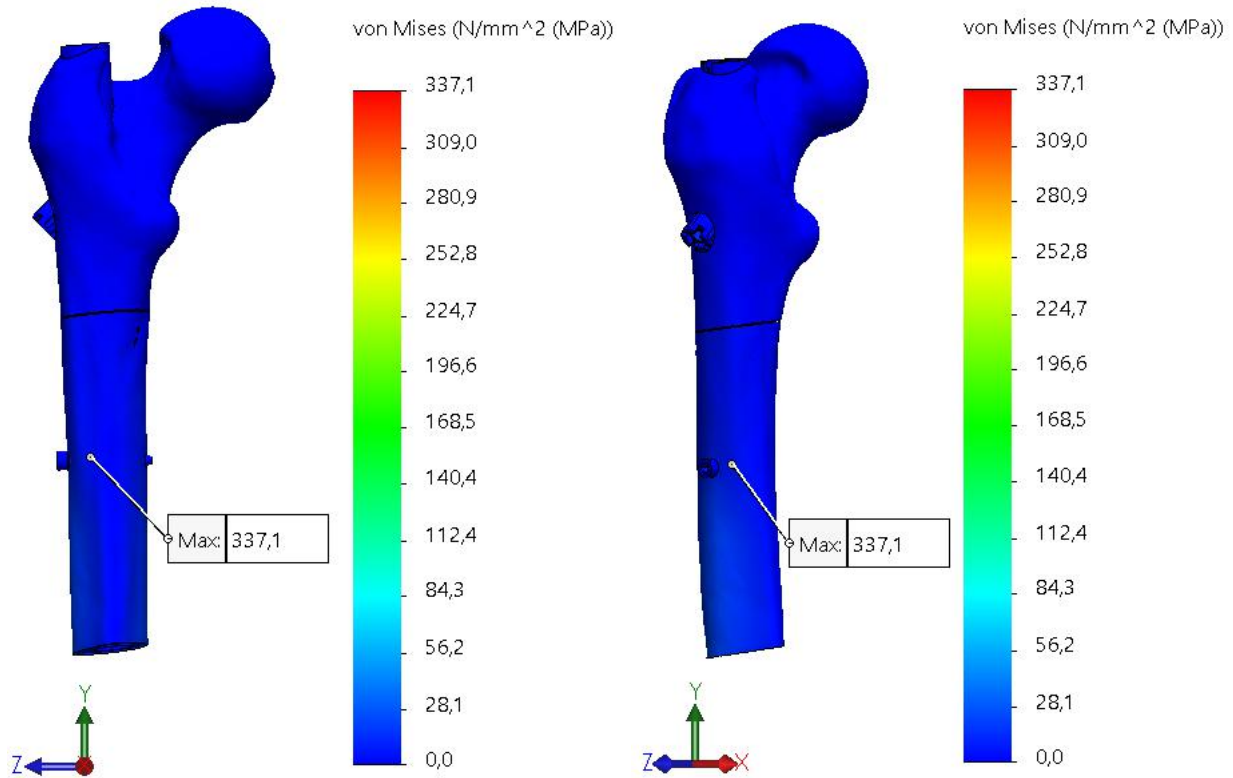

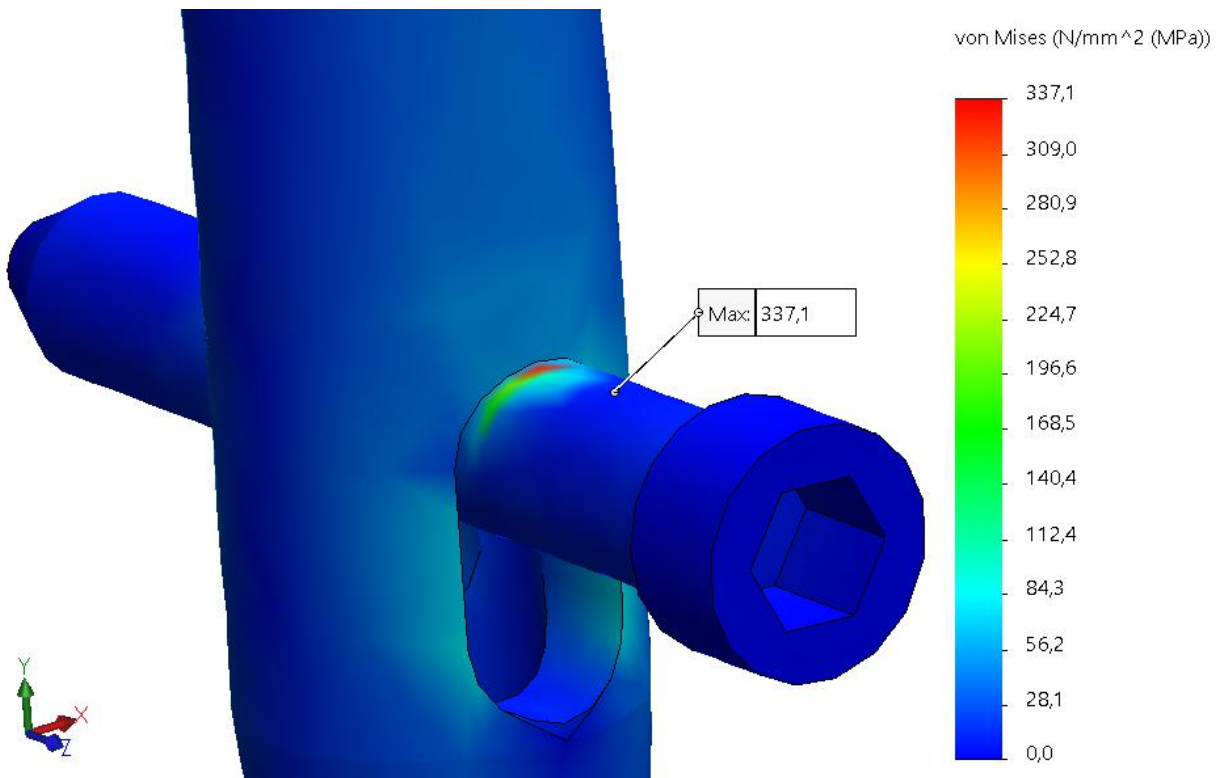
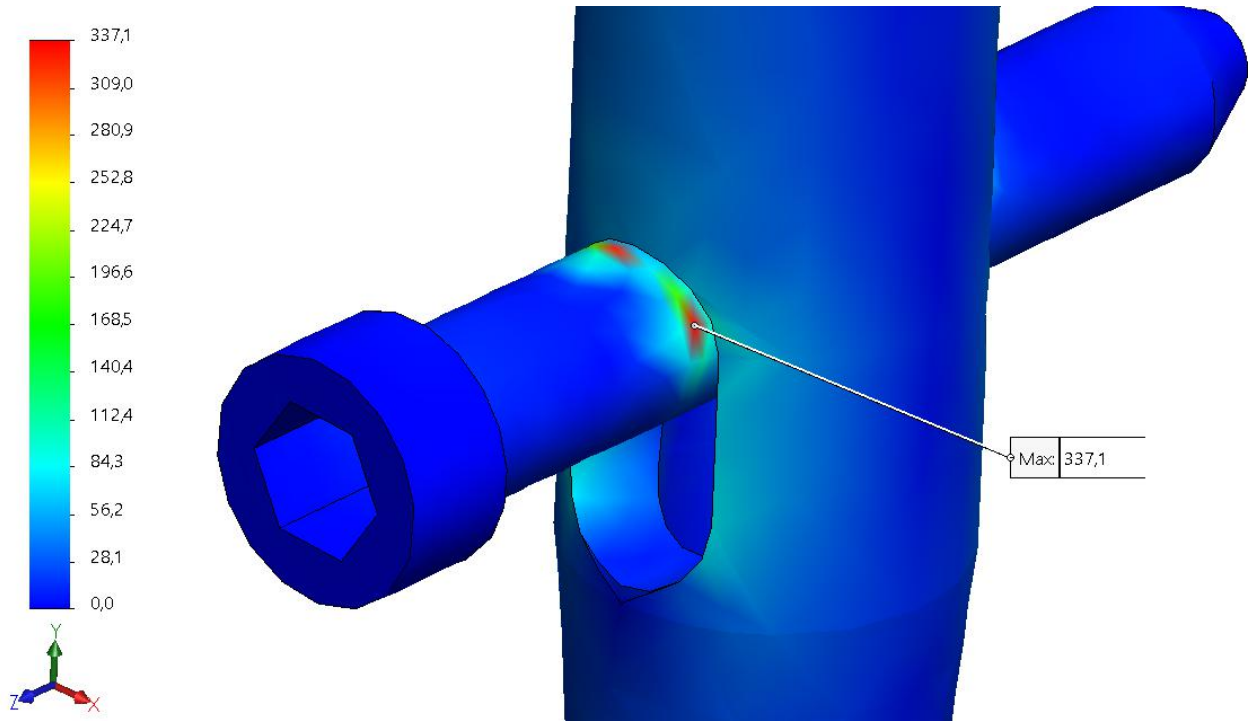

PFNA (location 5: 2.5 cm below LT)

Force: 125 N

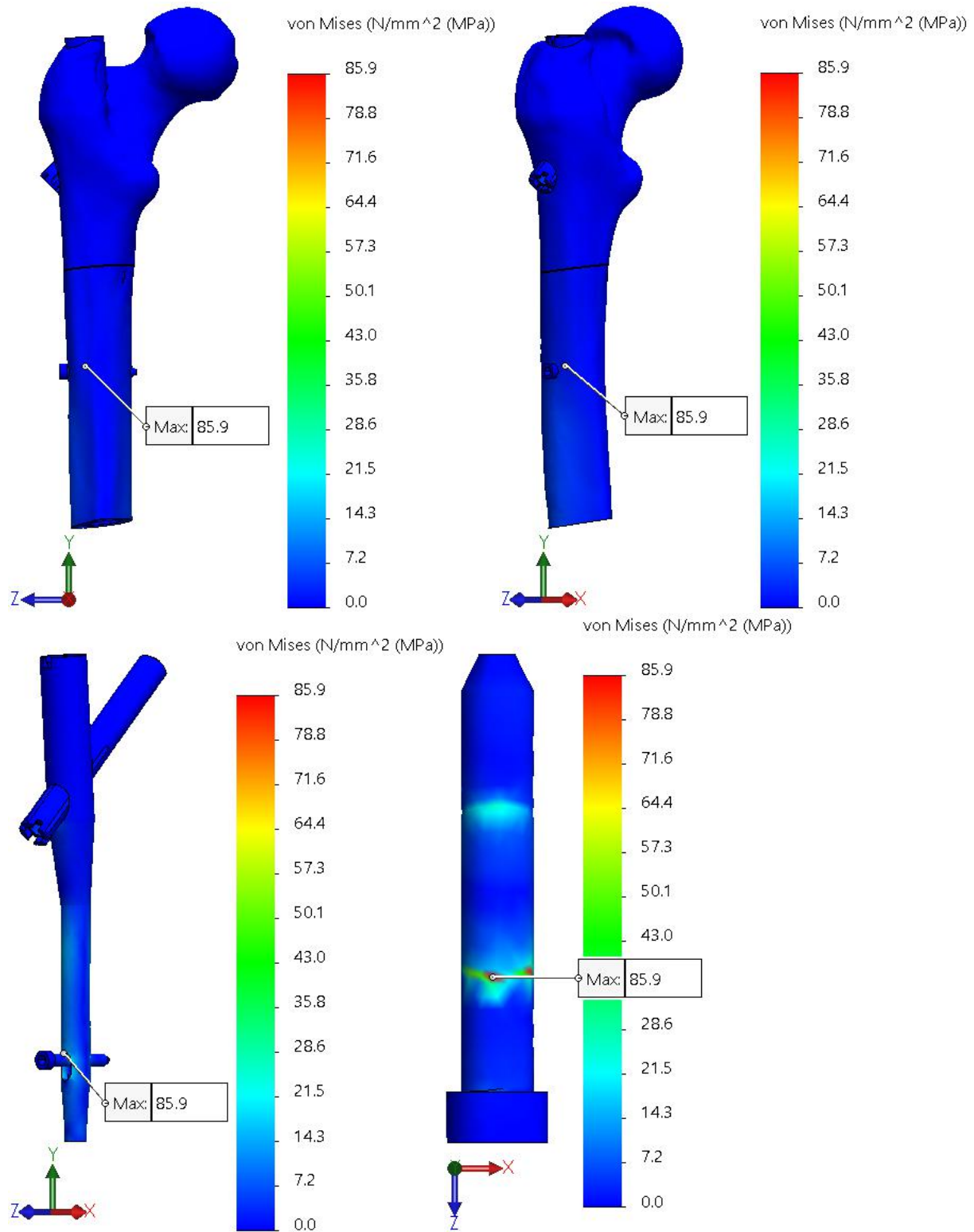

Force: 250 N

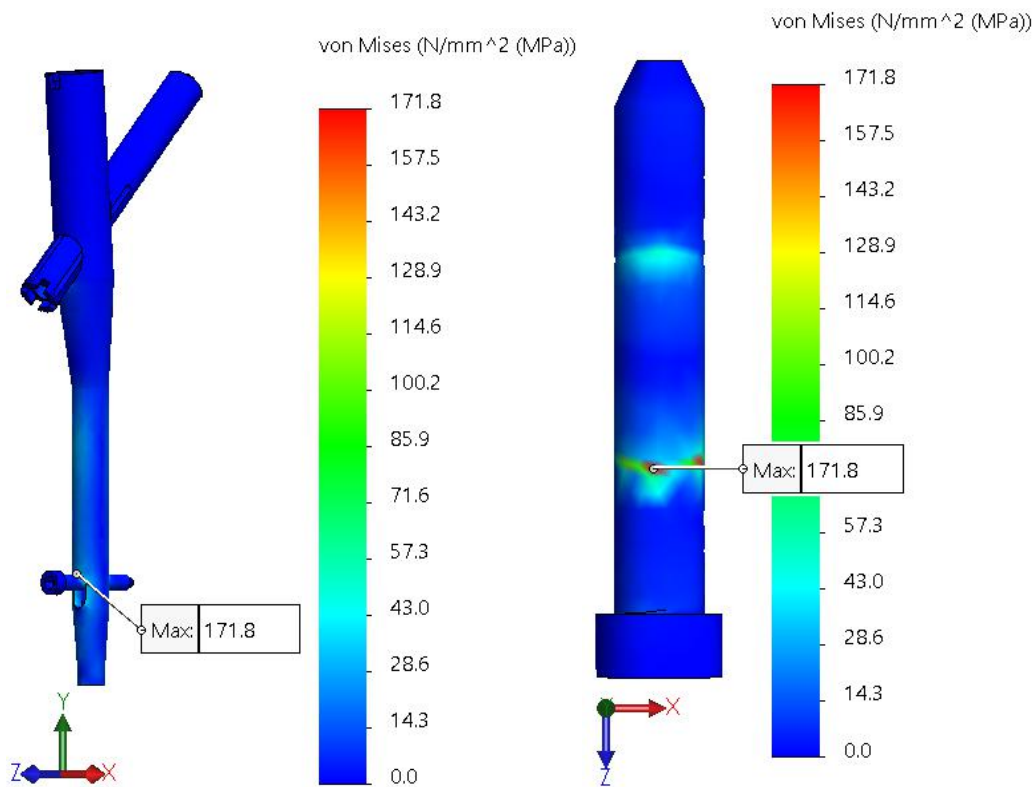
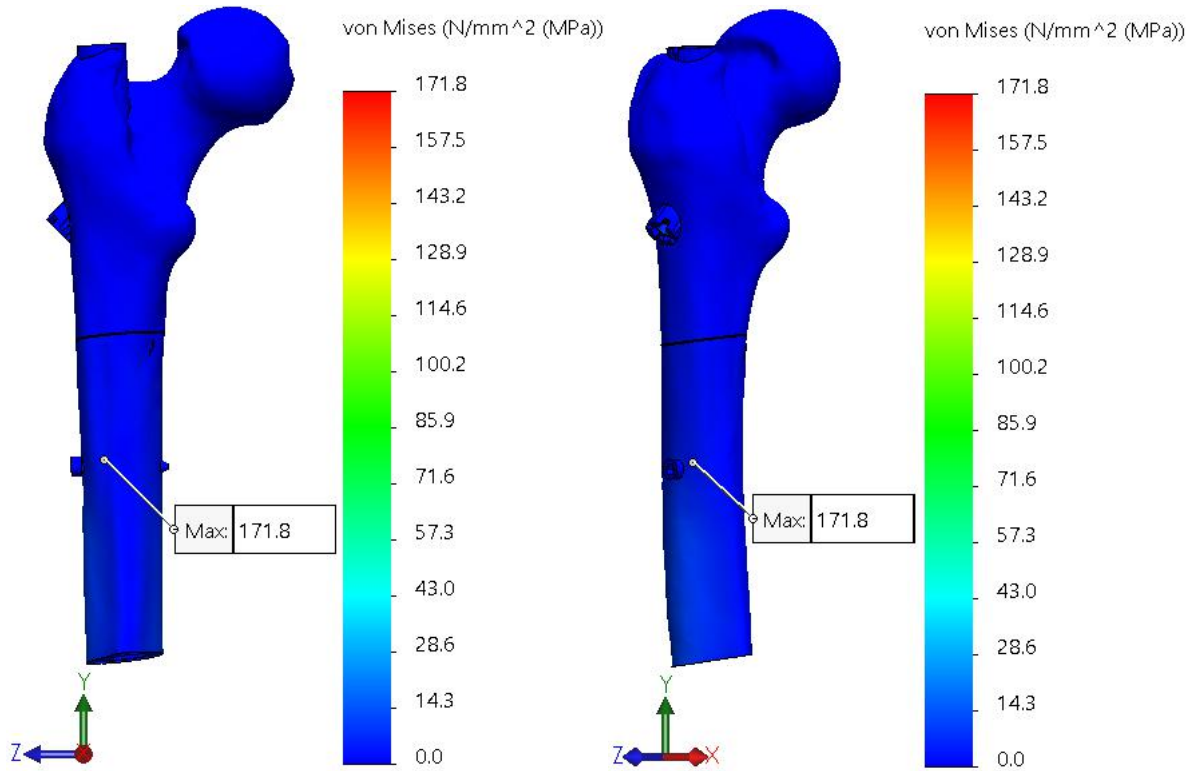

Force: 375 N

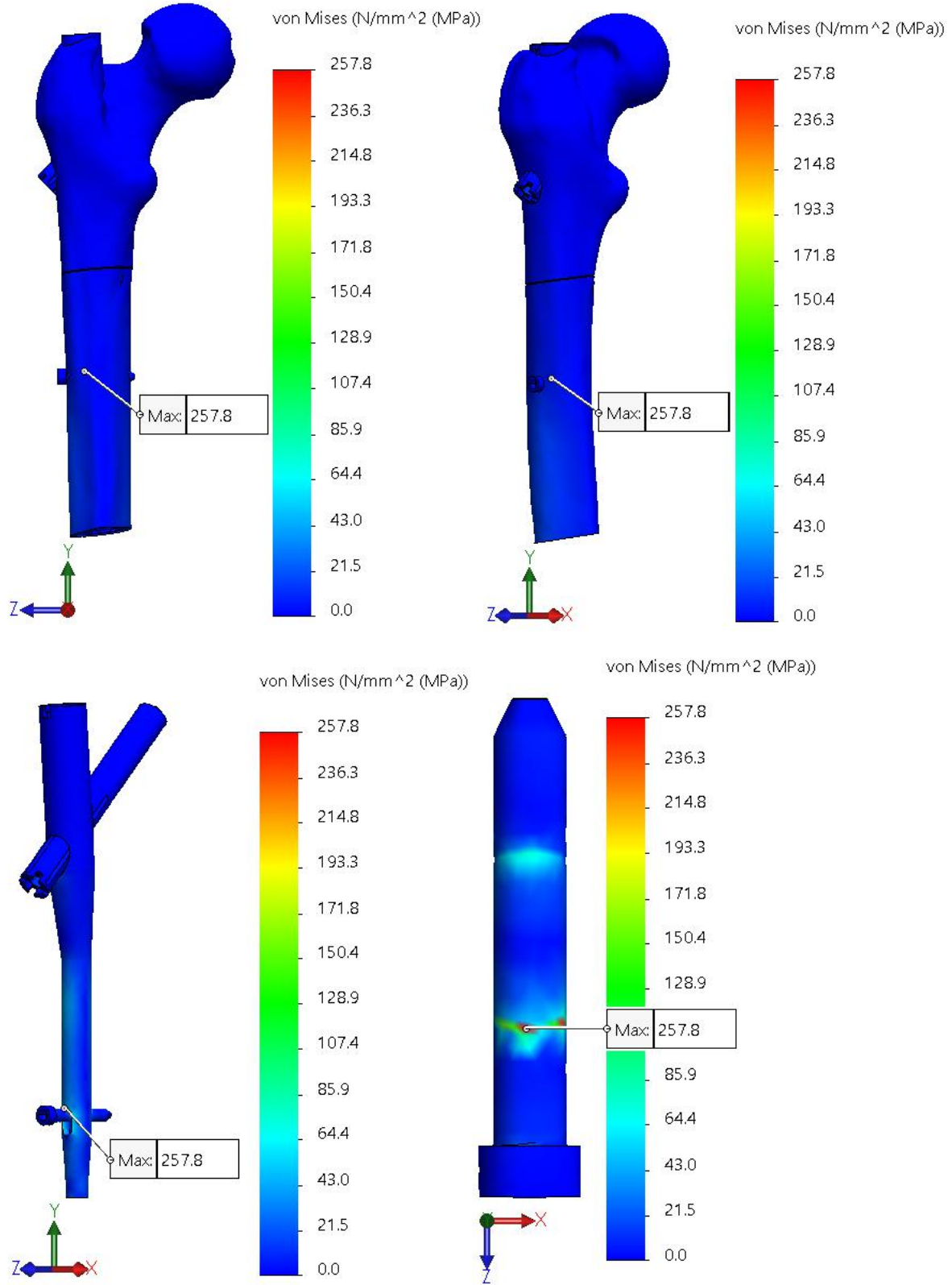

Force: 500 N

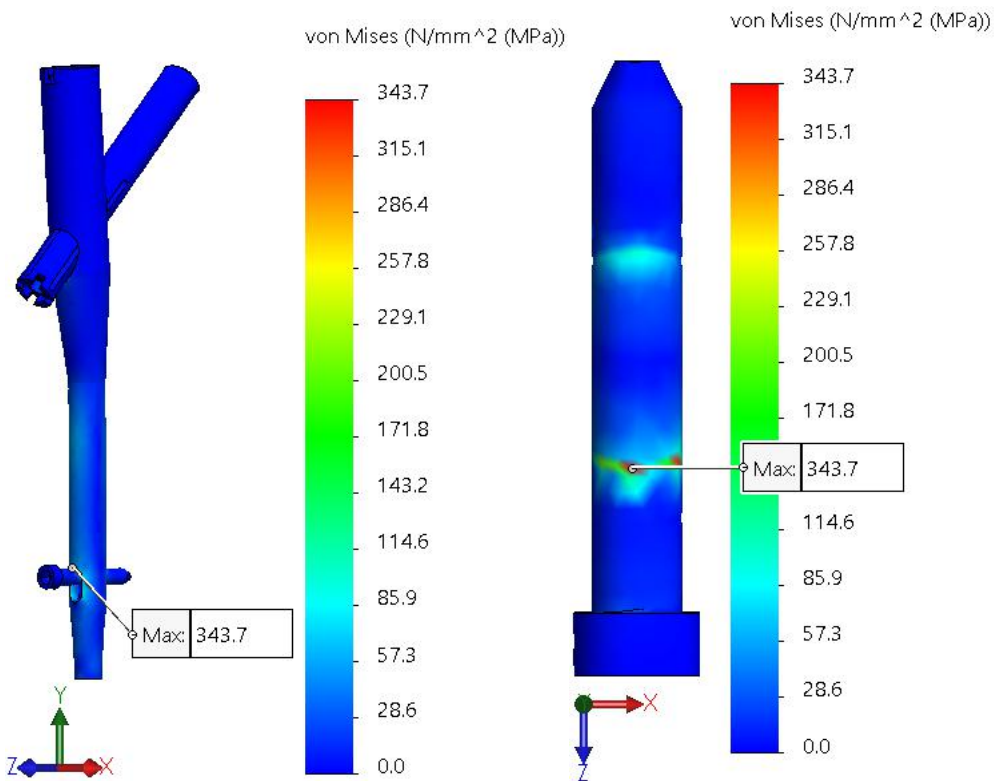
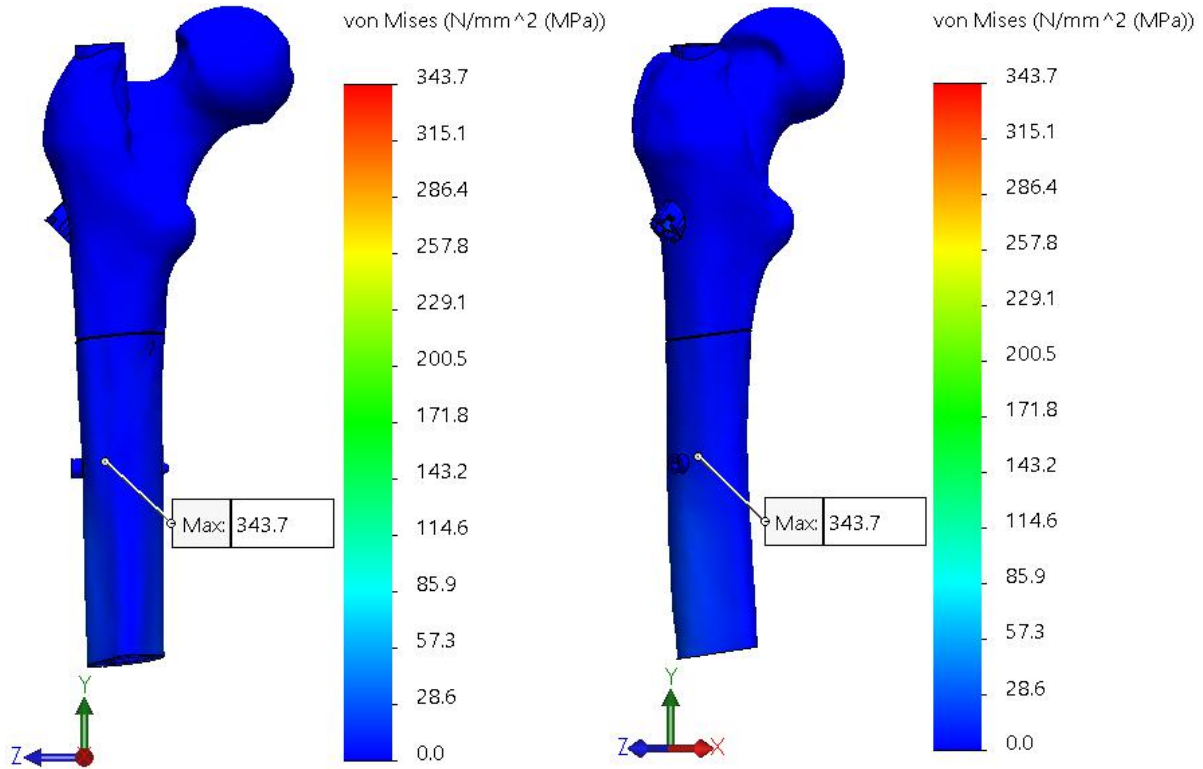

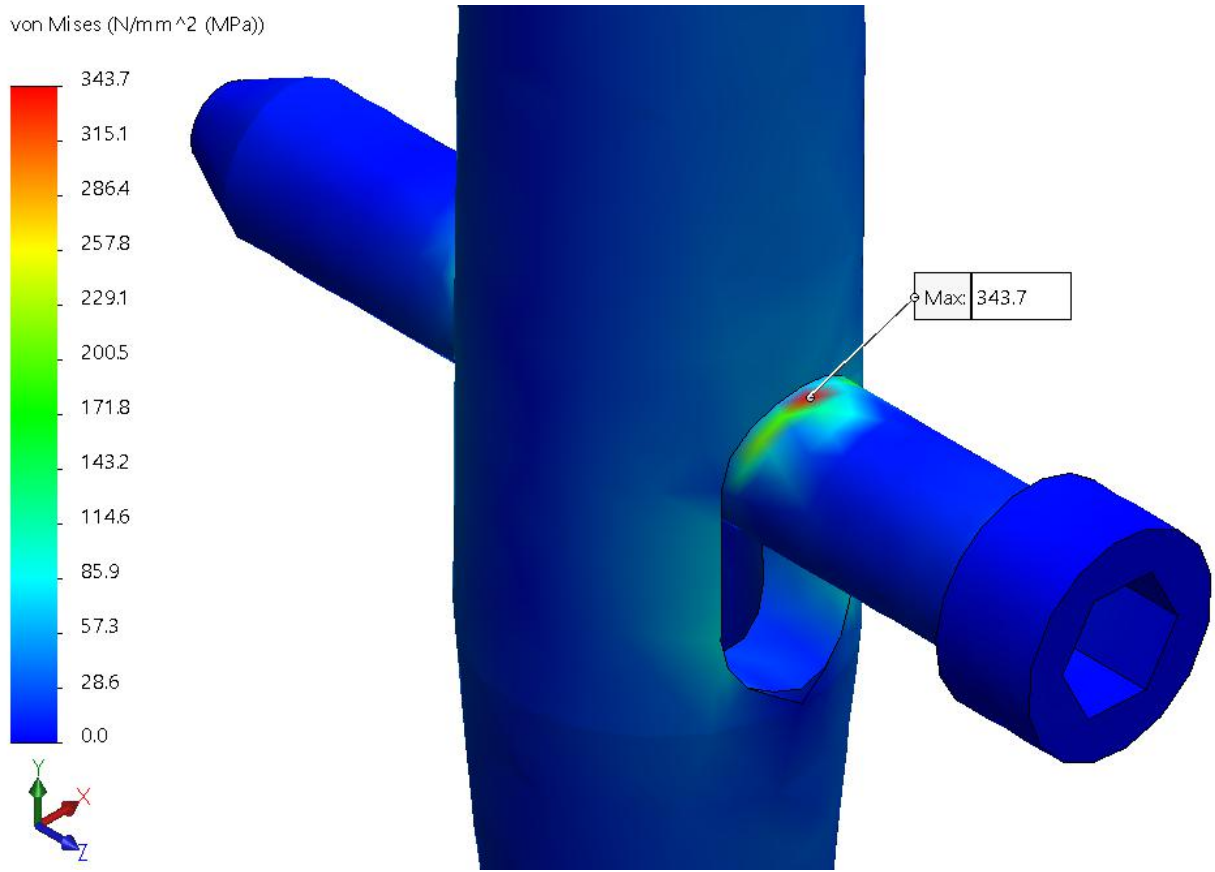
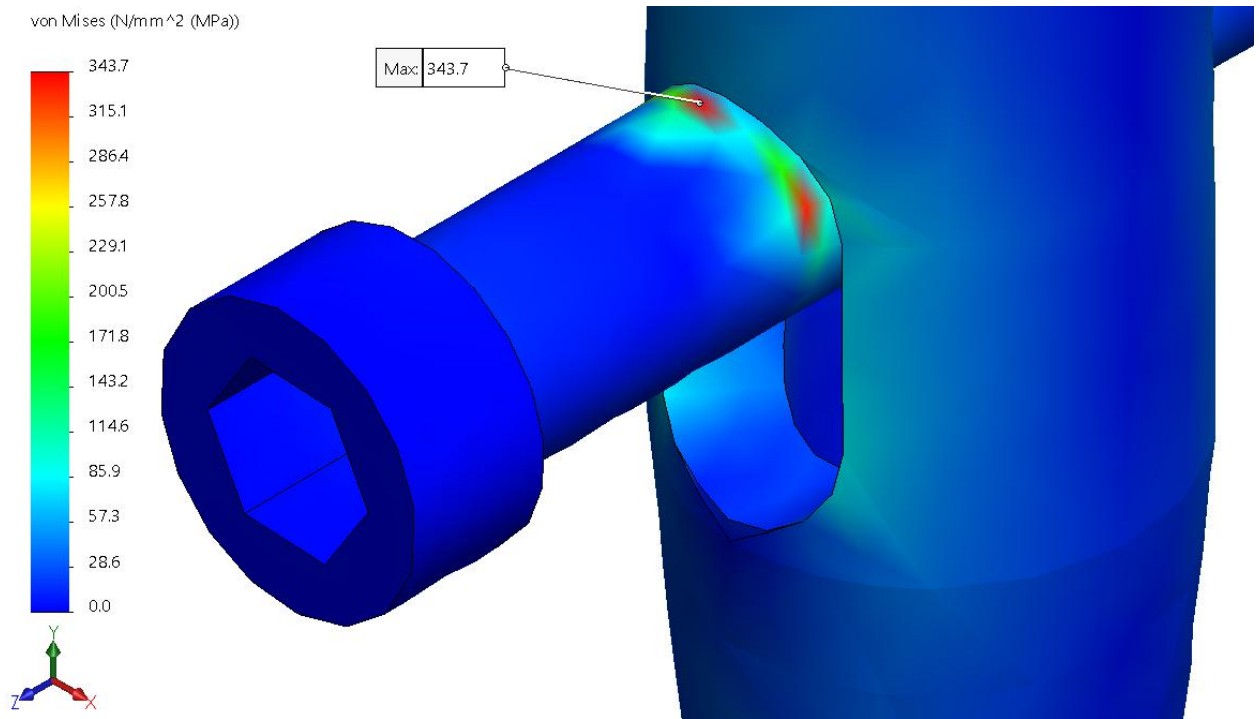

PFNA (location 6: 3 cm below LT)

Force: 125 N

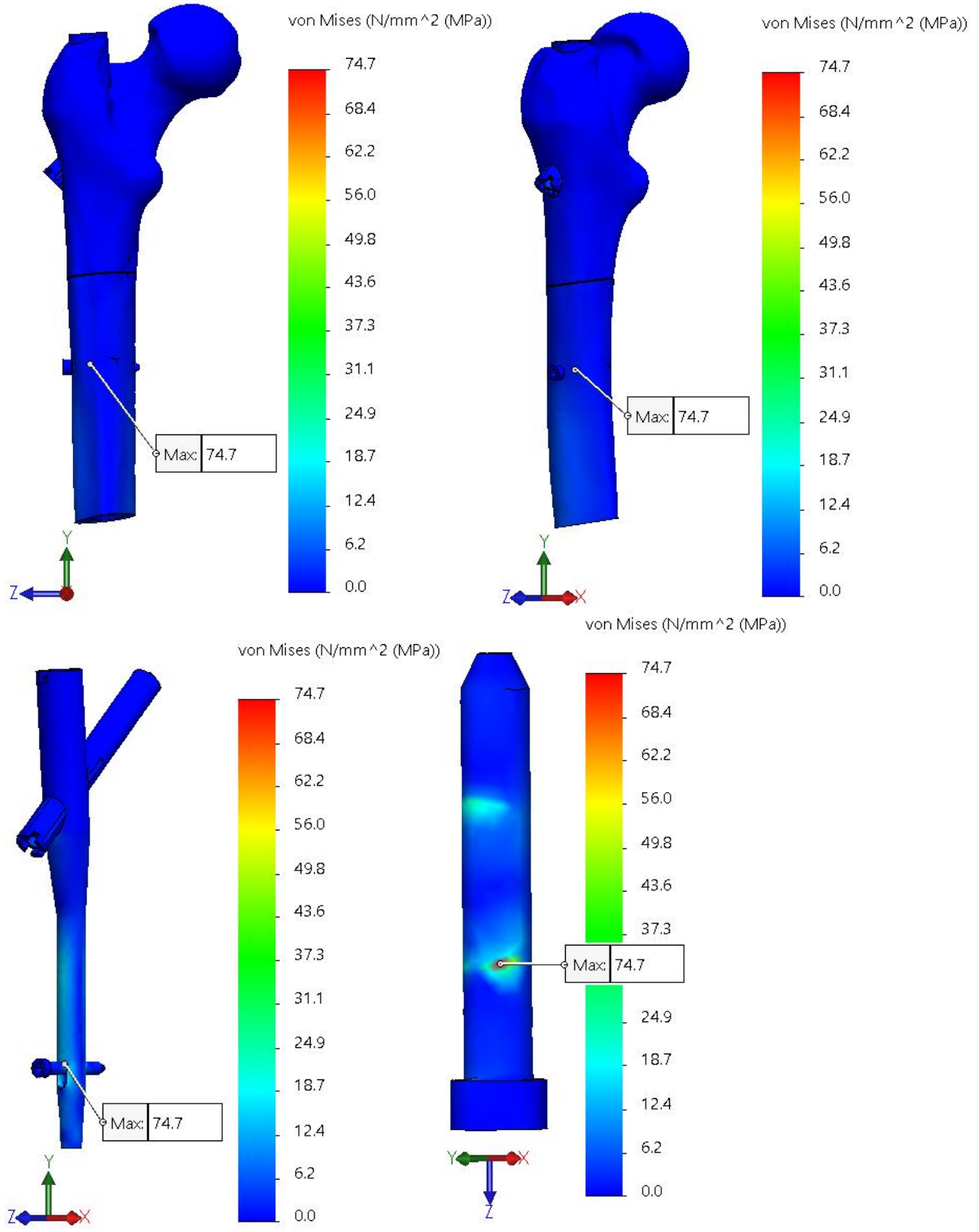

Force: 250 N

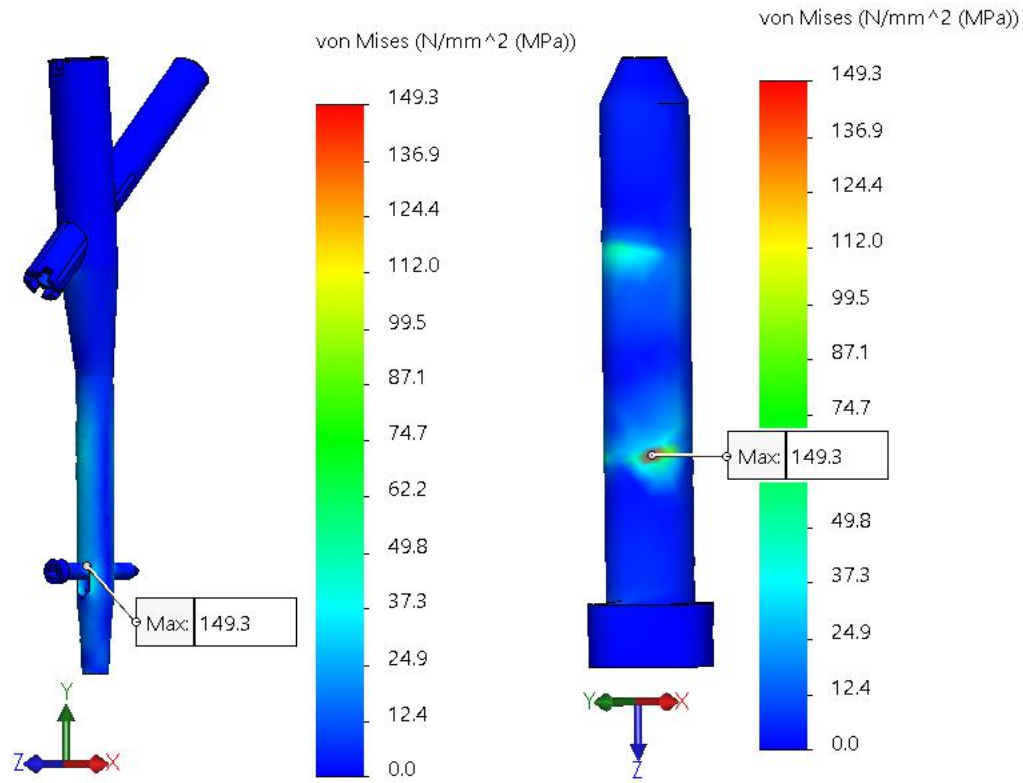
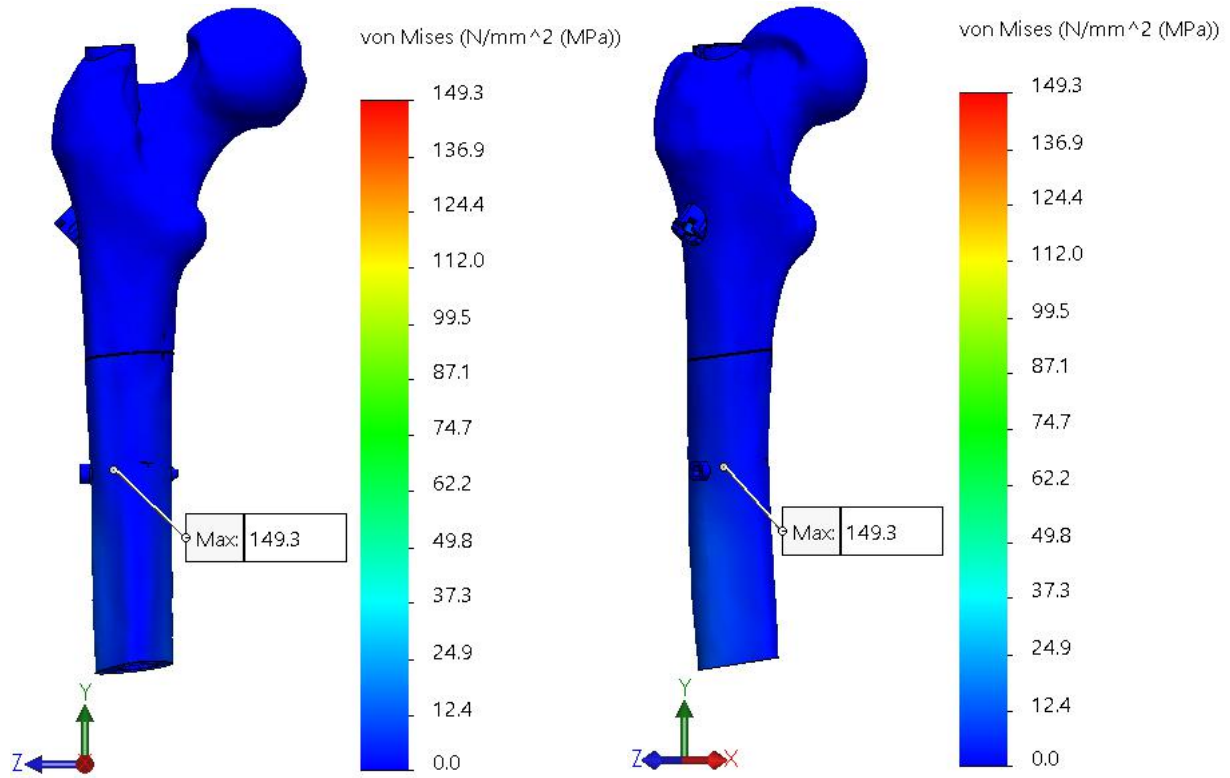

Force: 375 N

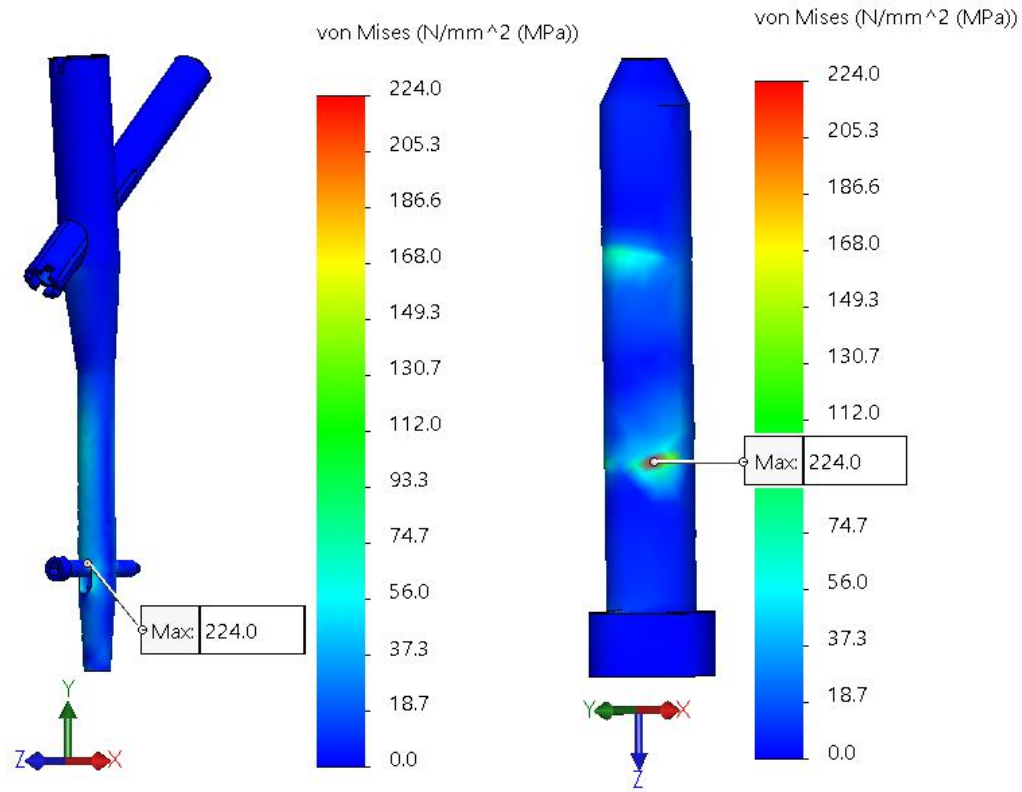
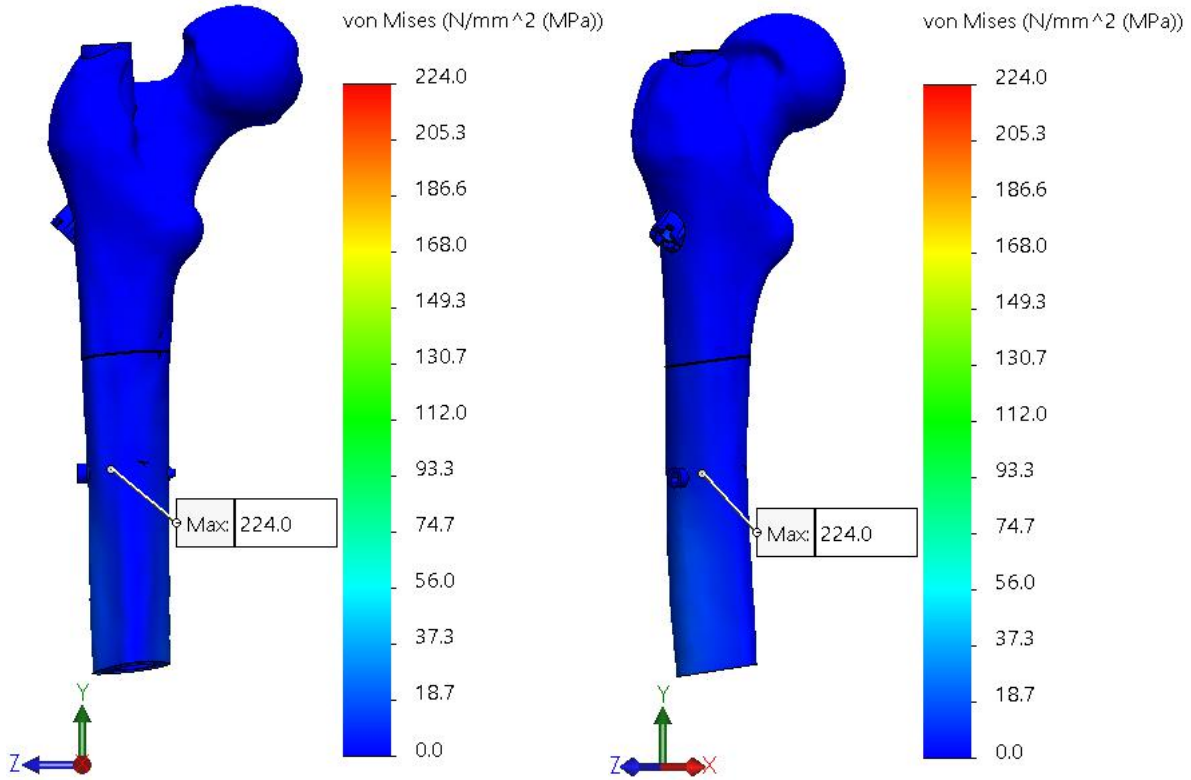

Force: 500 N

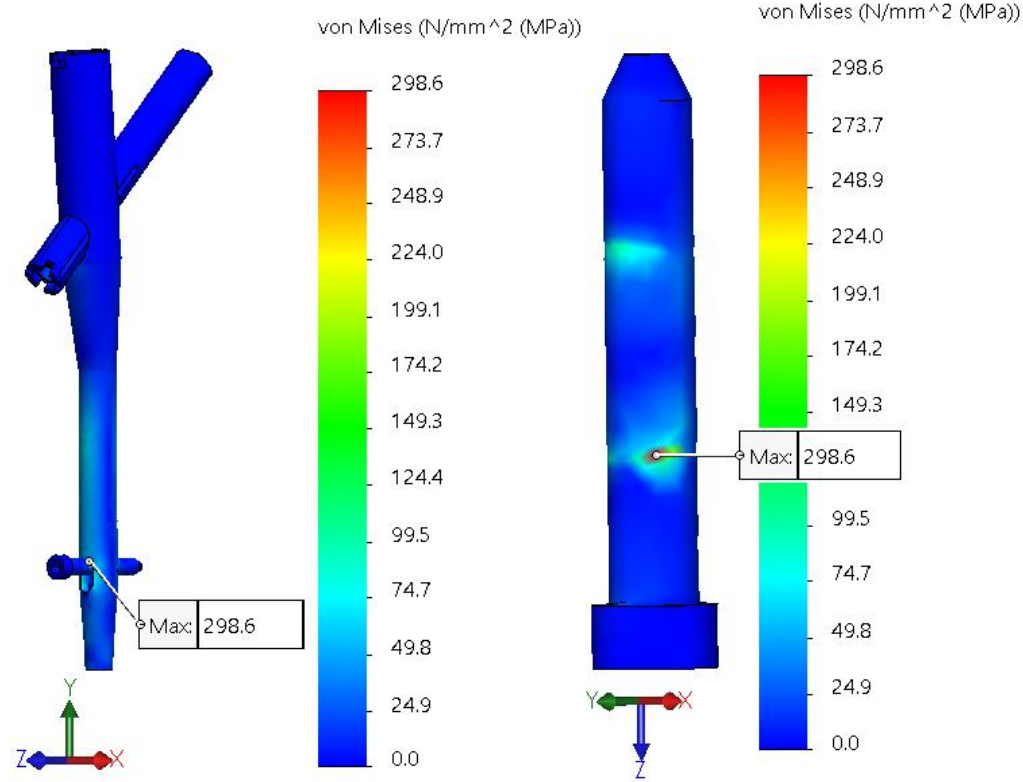
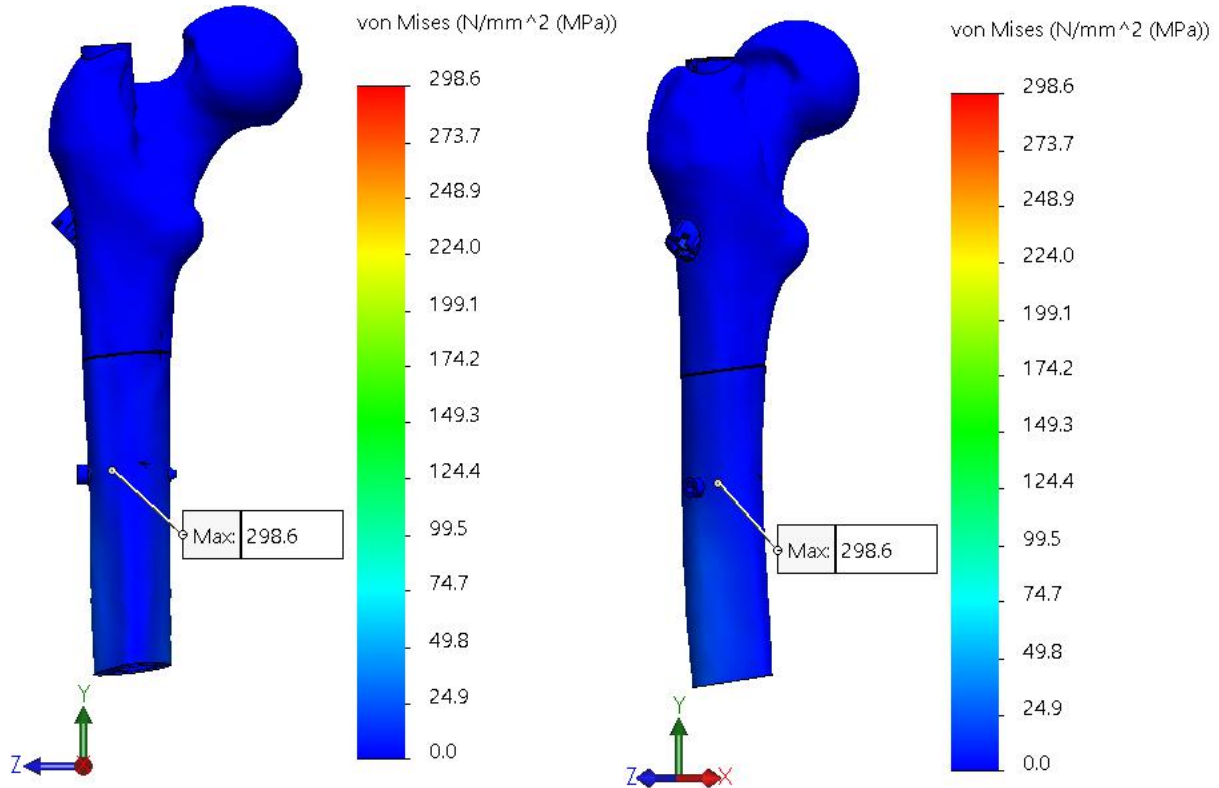

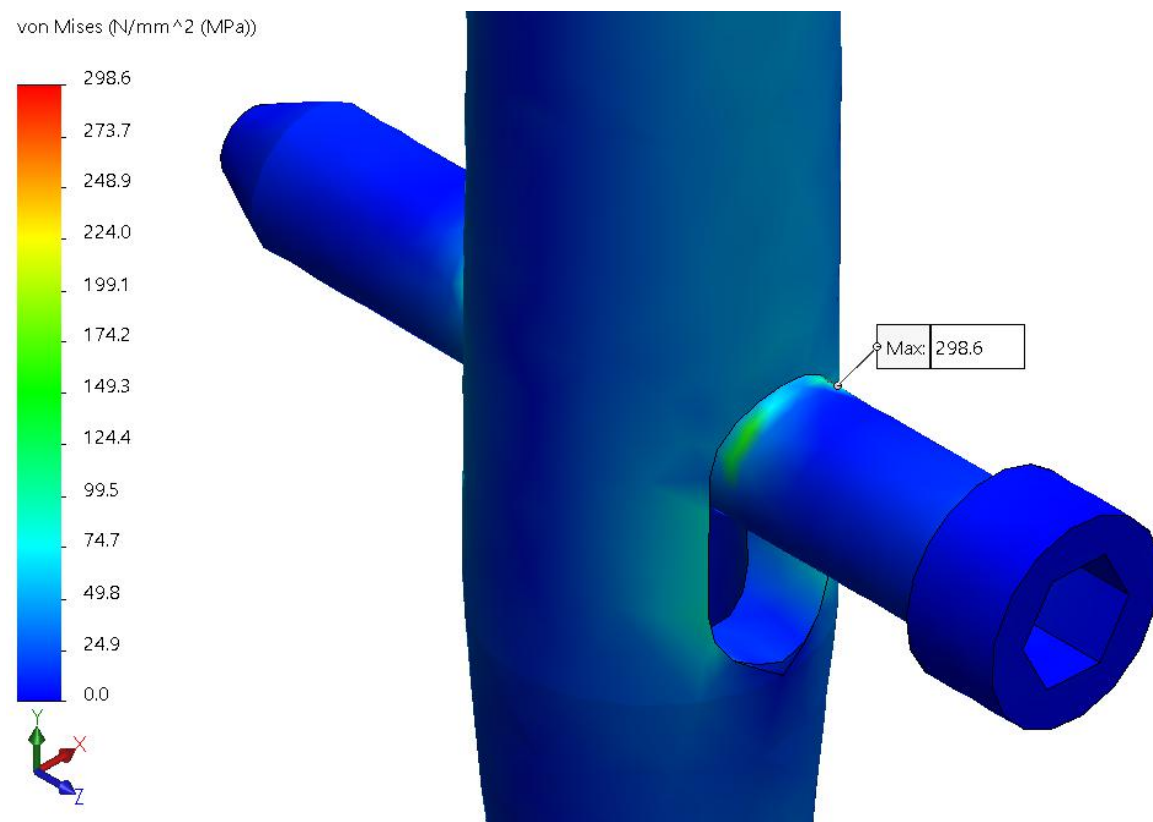
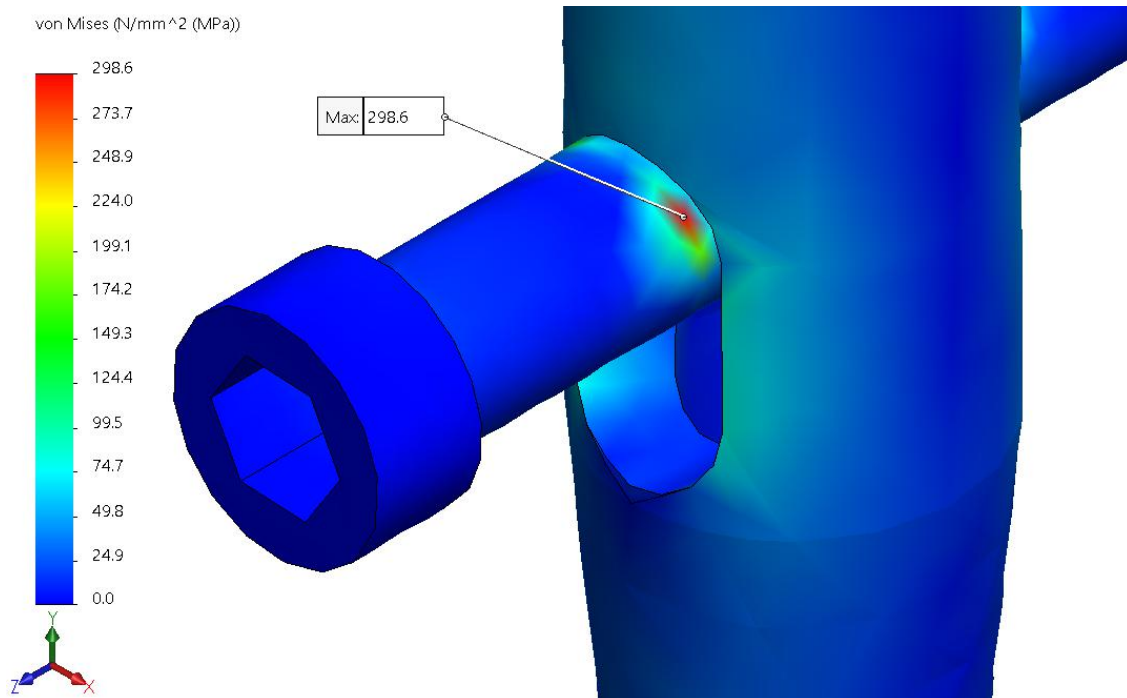

PFNA (location 7: 3.5 cm below LT)

Force: 125 N

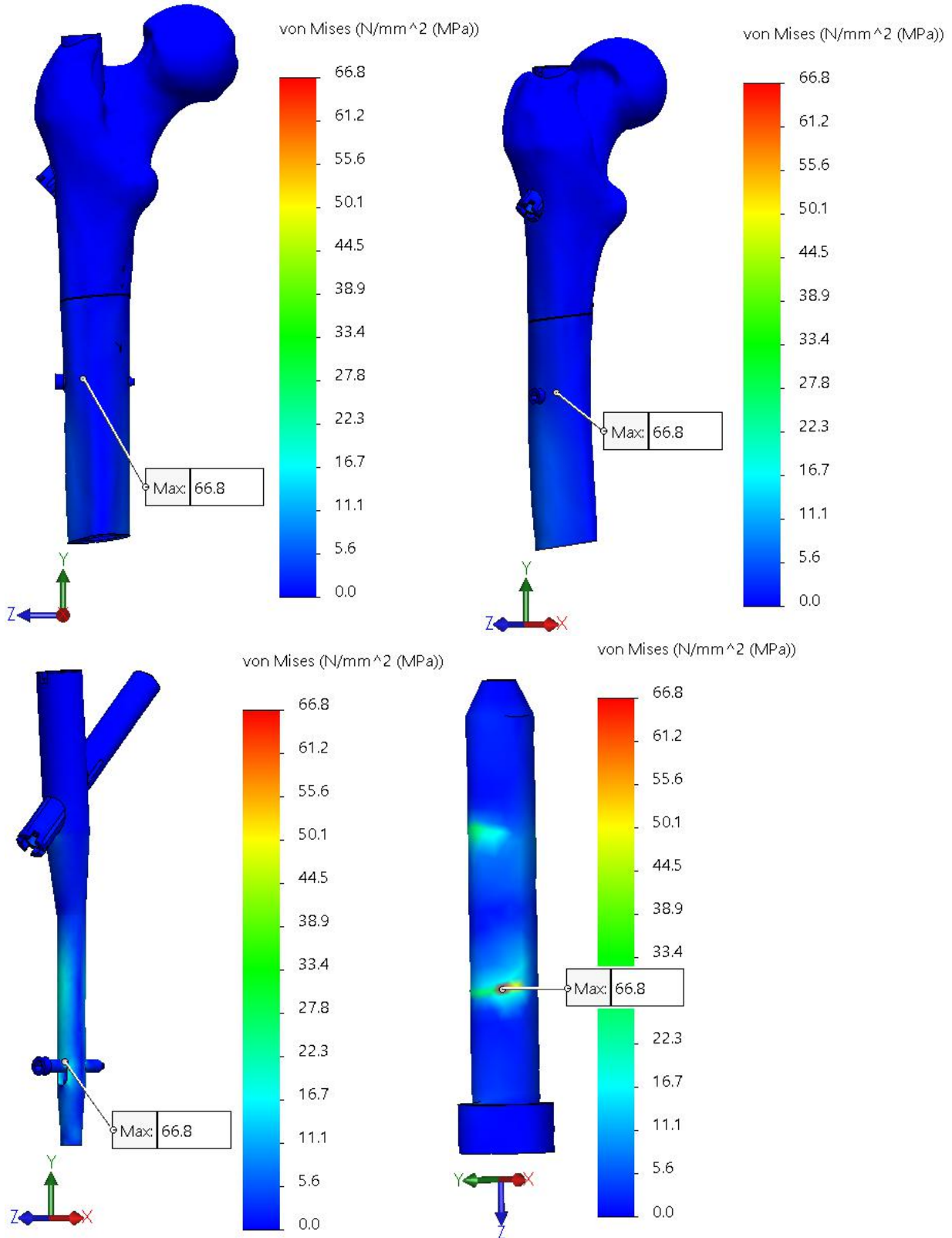

Force: 250 N

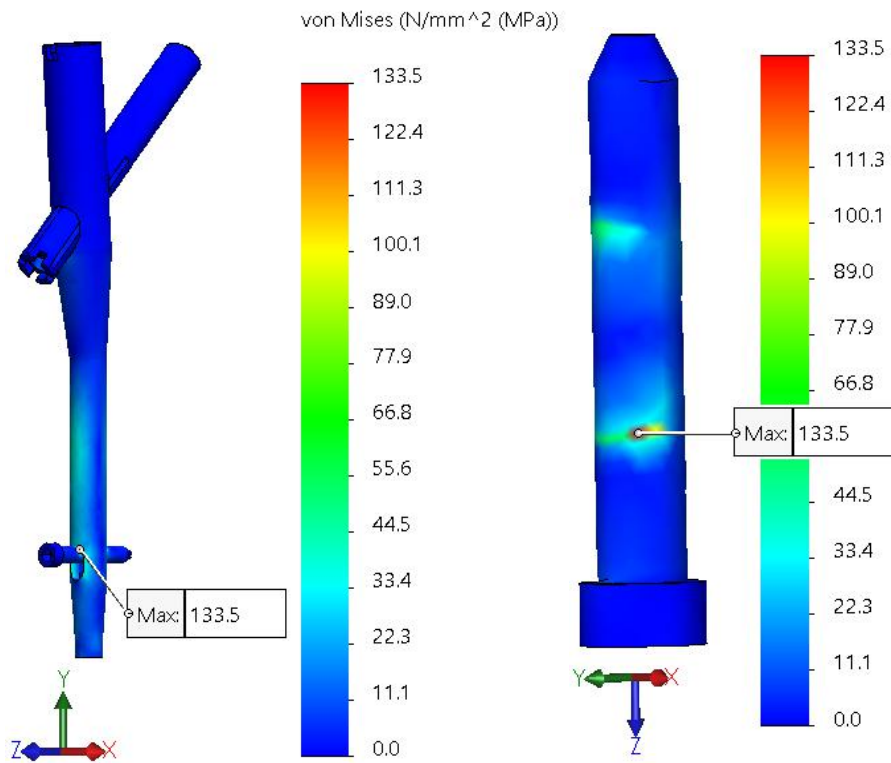
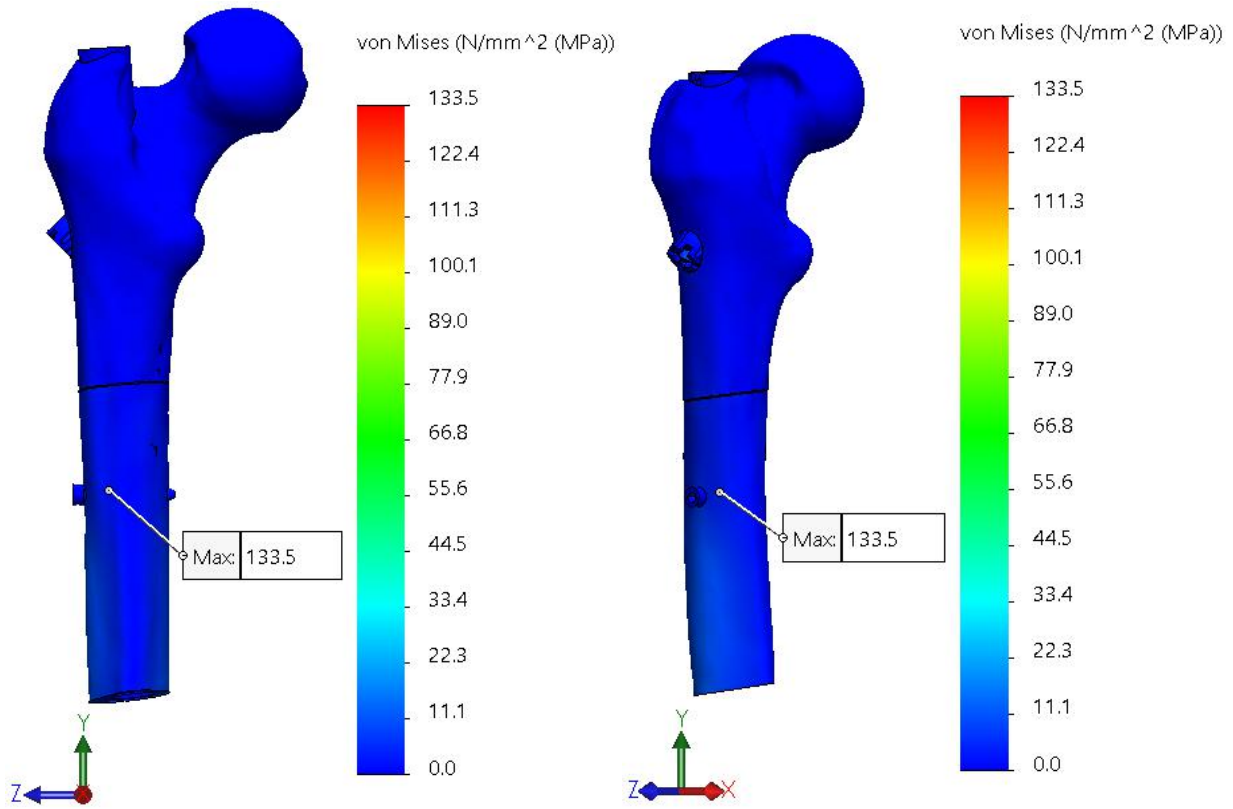

Force: 375 N

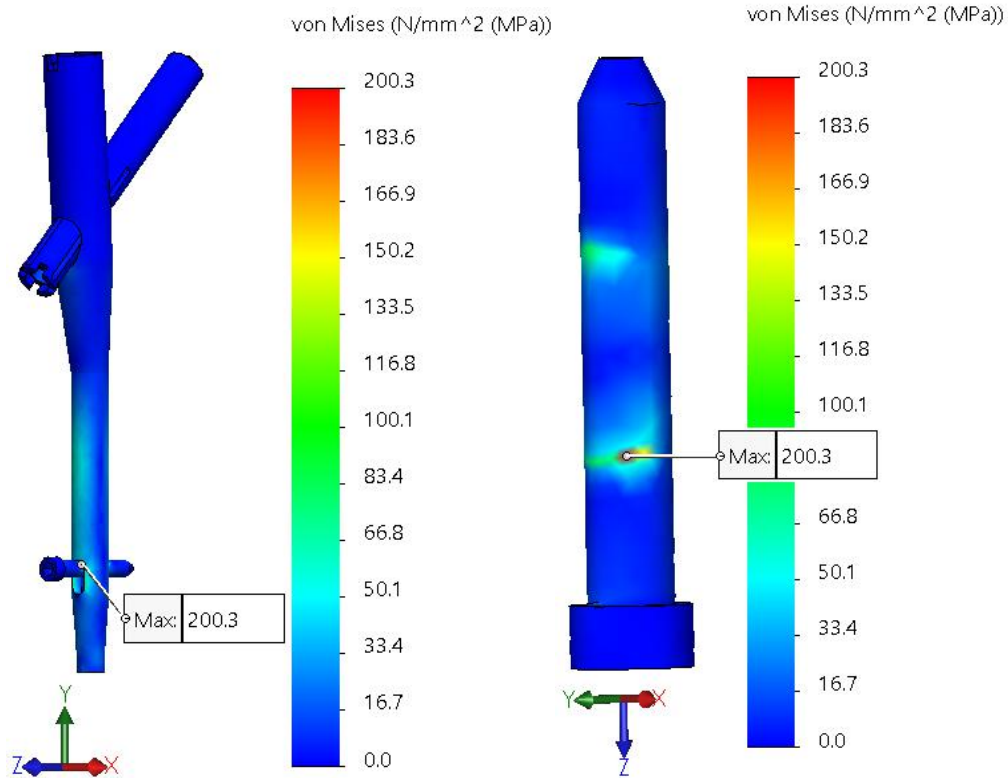
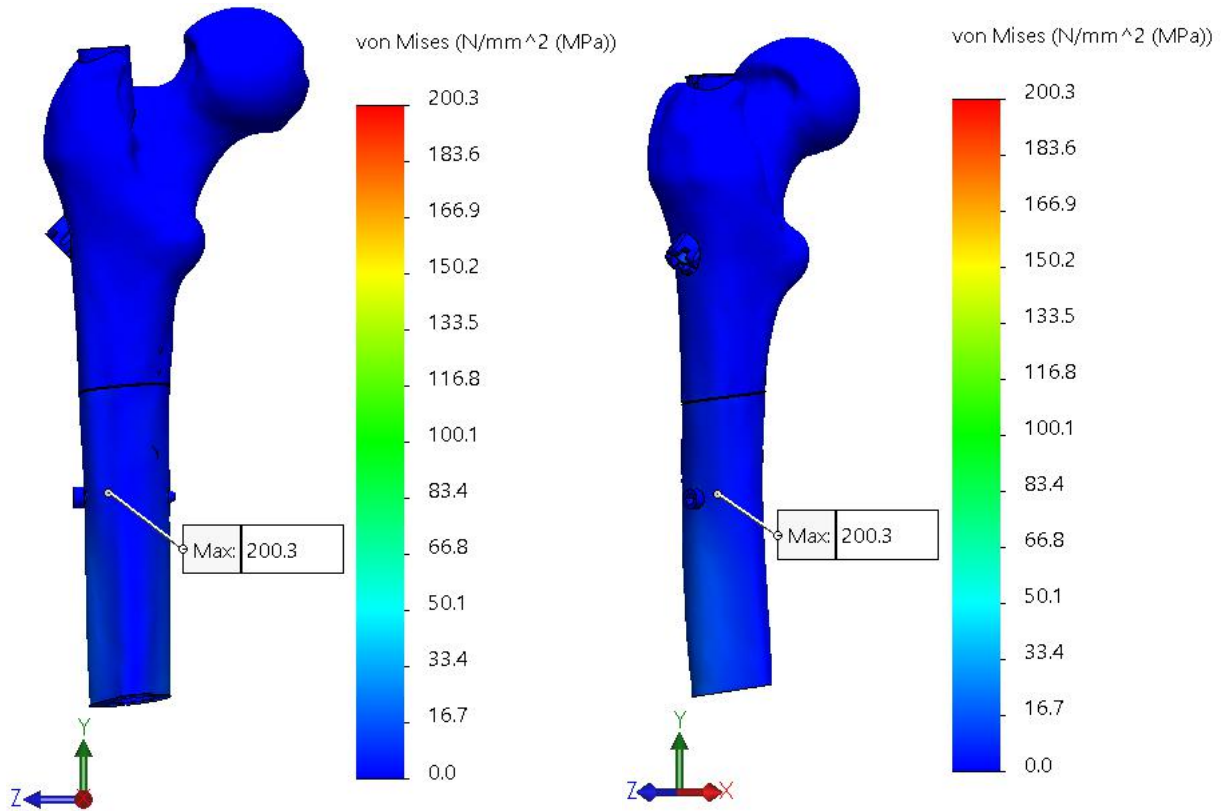

Force: 500 N

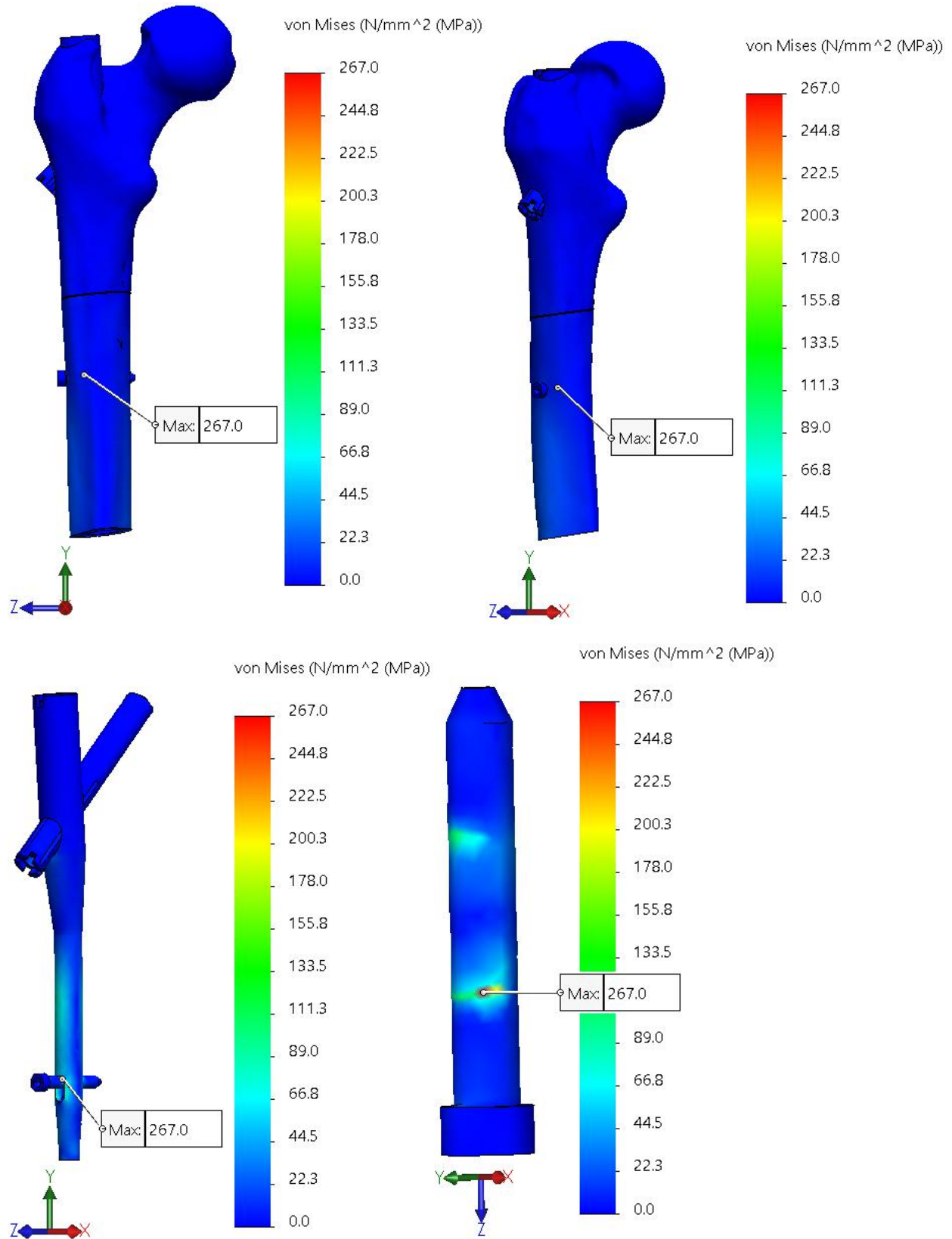

von Mises (N/mm² (MPa))

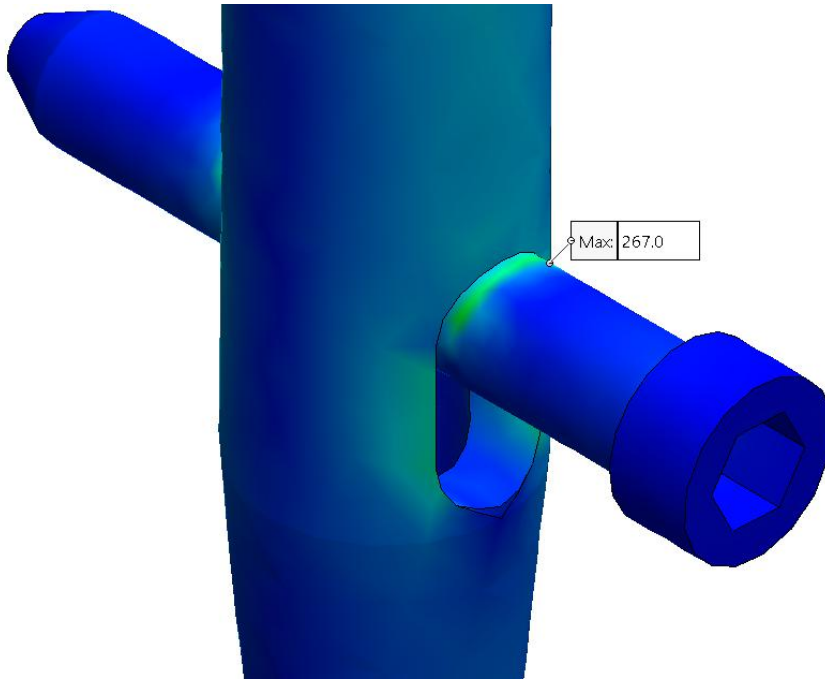
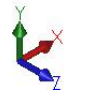
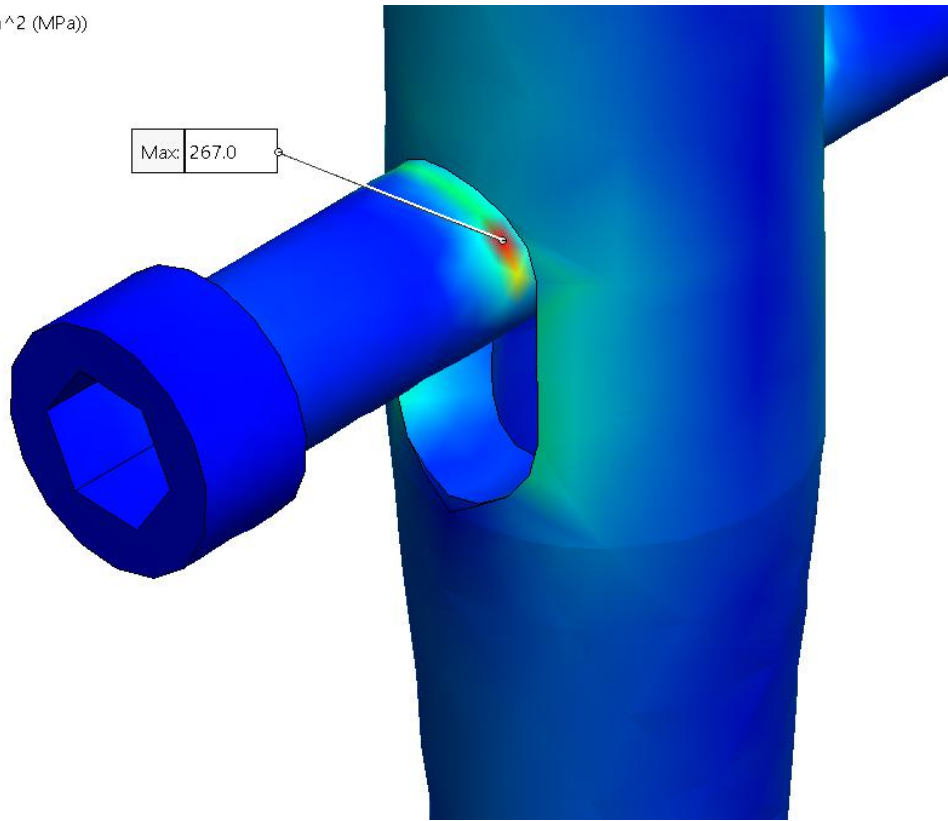
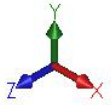
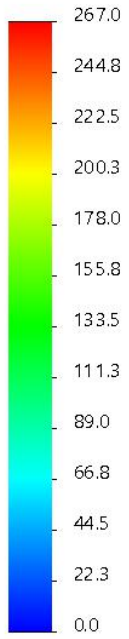

PFNA (location 8: 4 cm below LT)

Force: 125 N

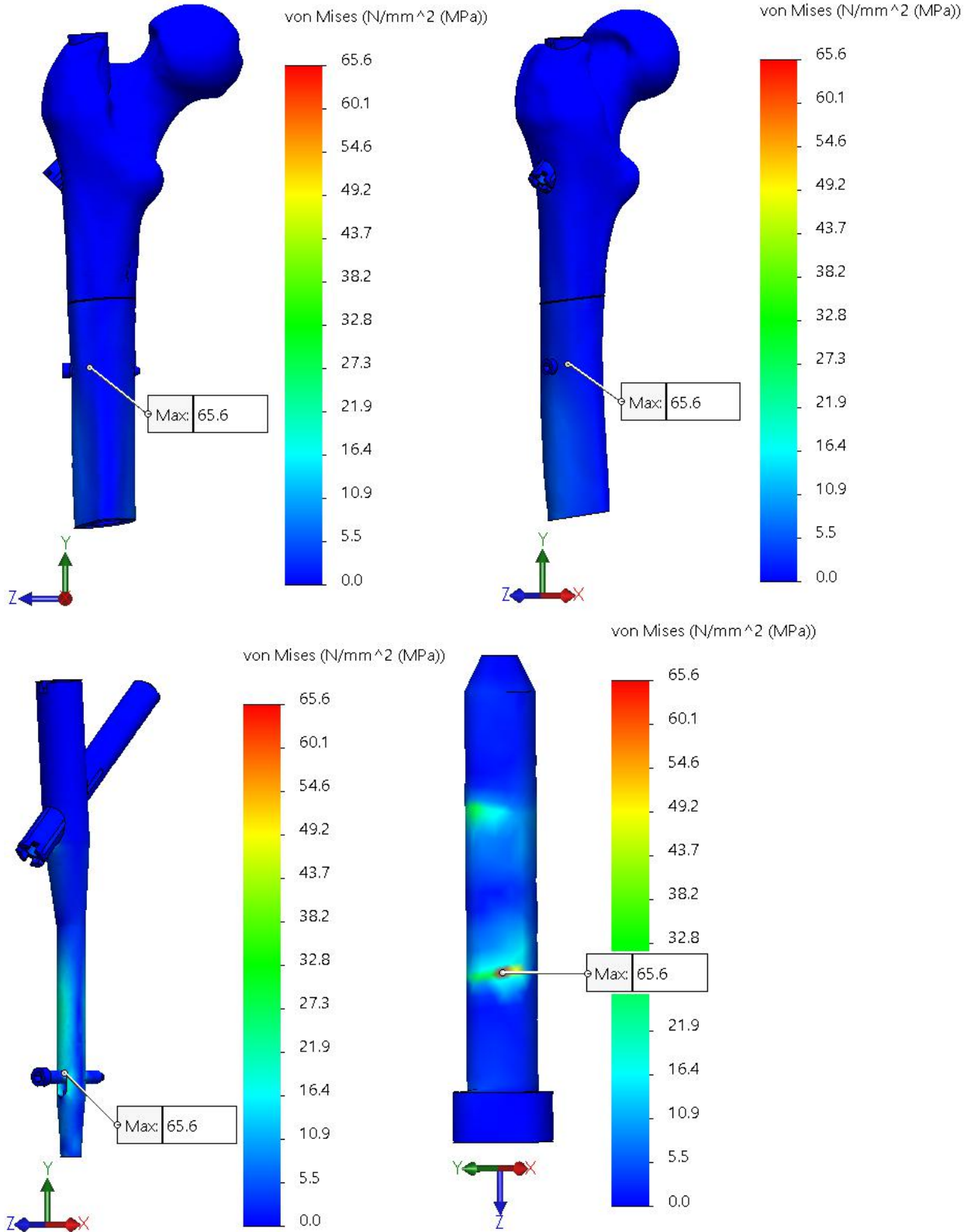

Force: 250 N

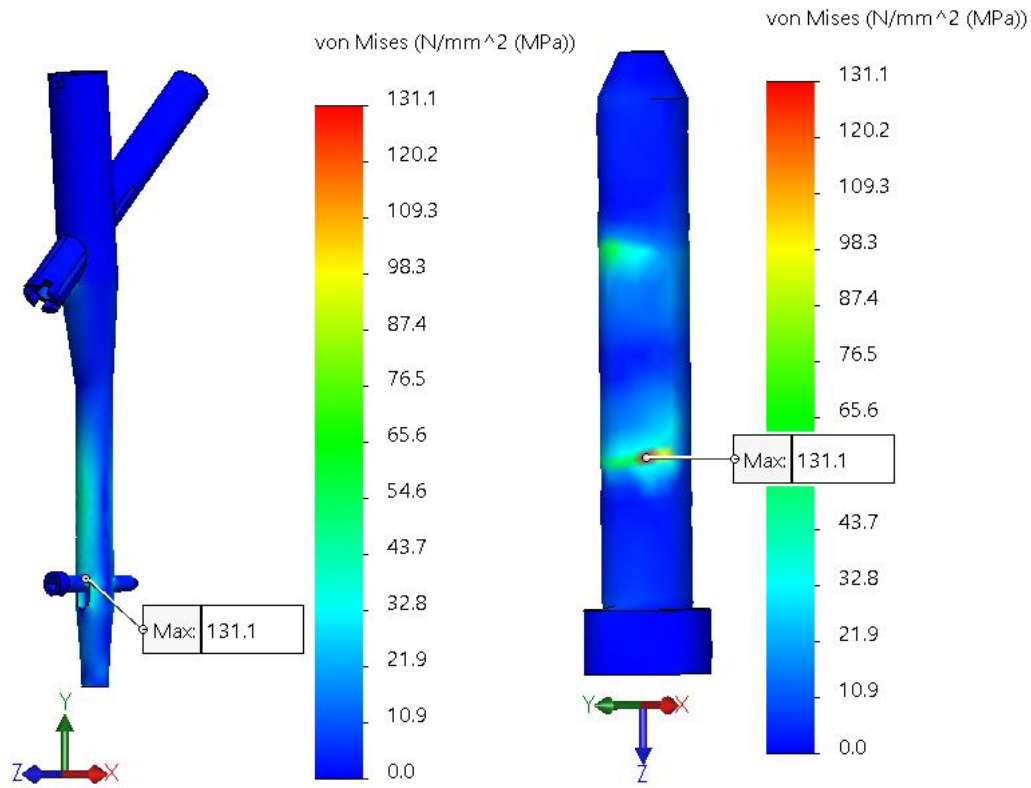
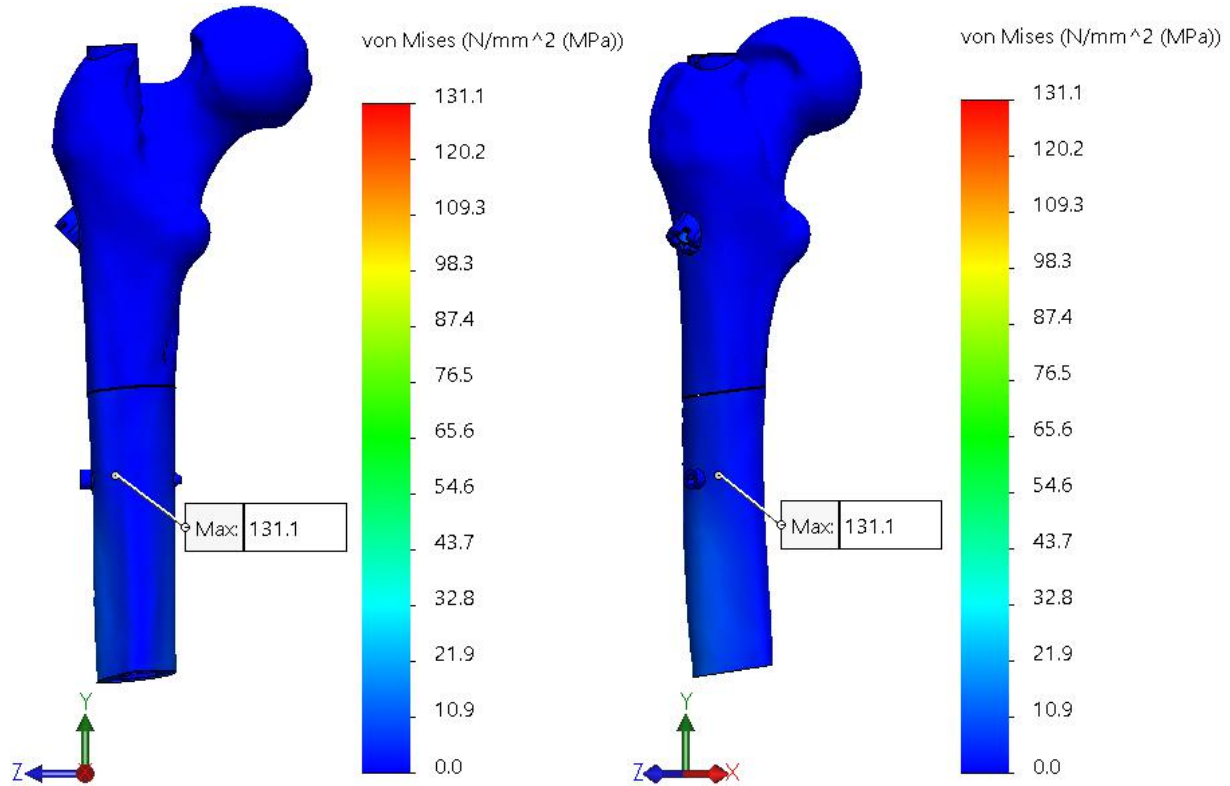

Force: 375 N

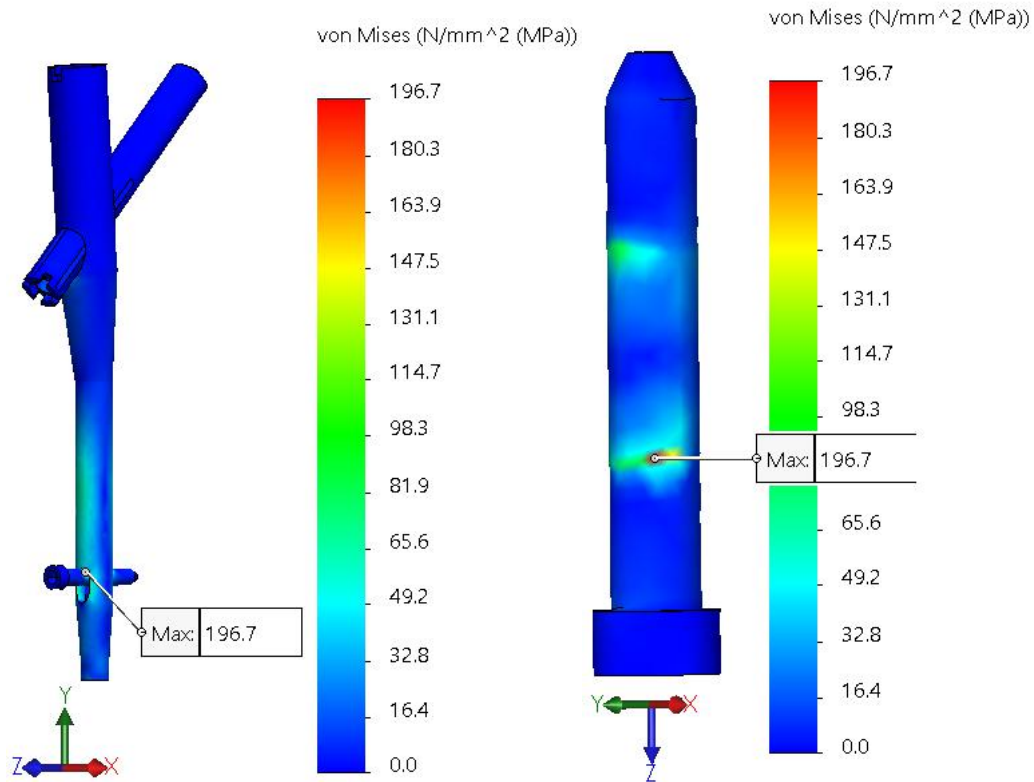
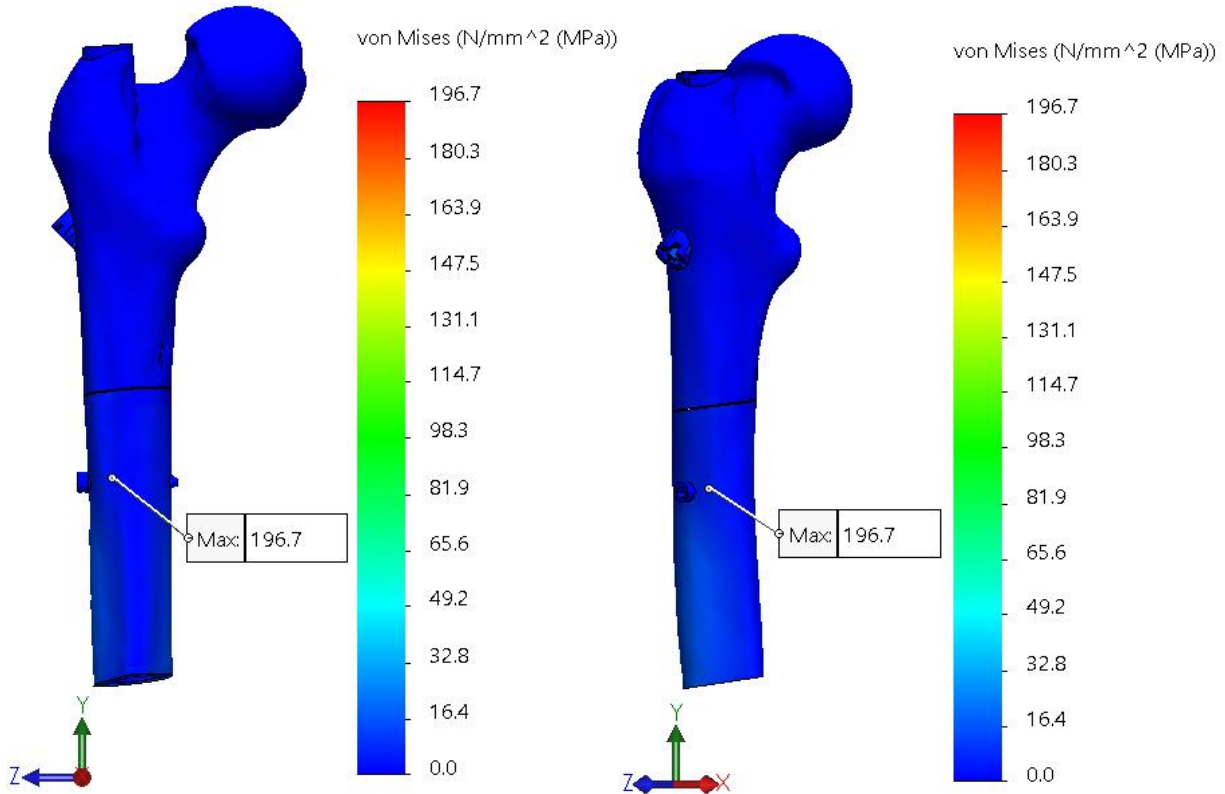

Force: 500 N

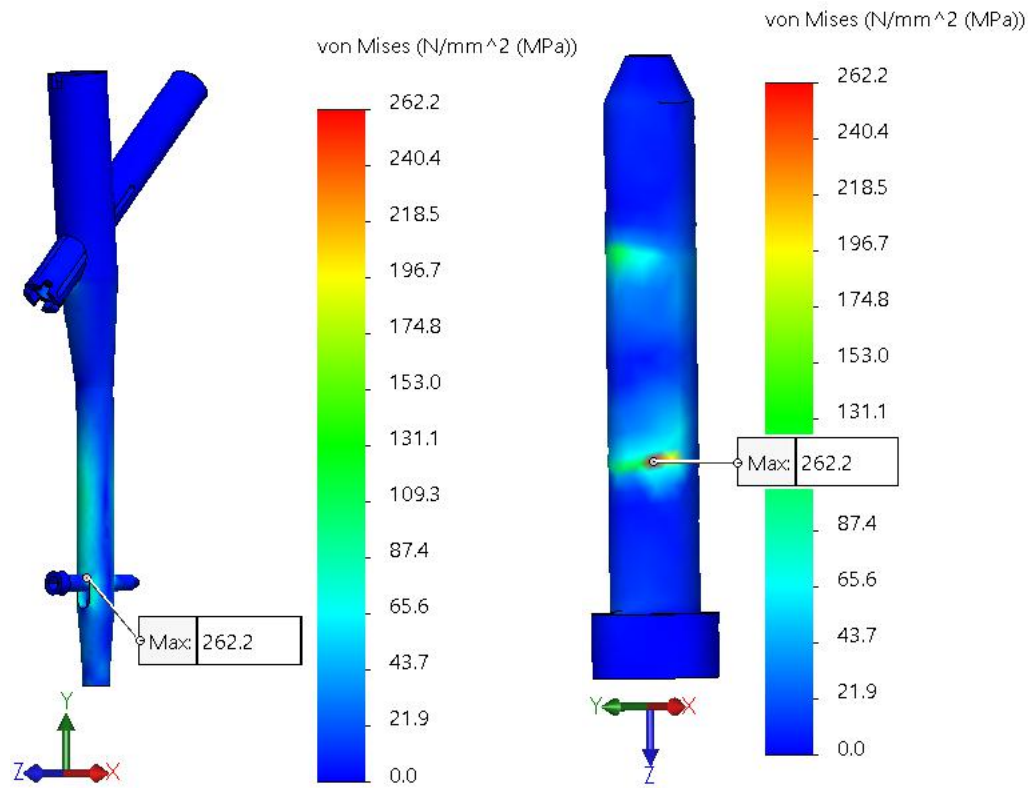
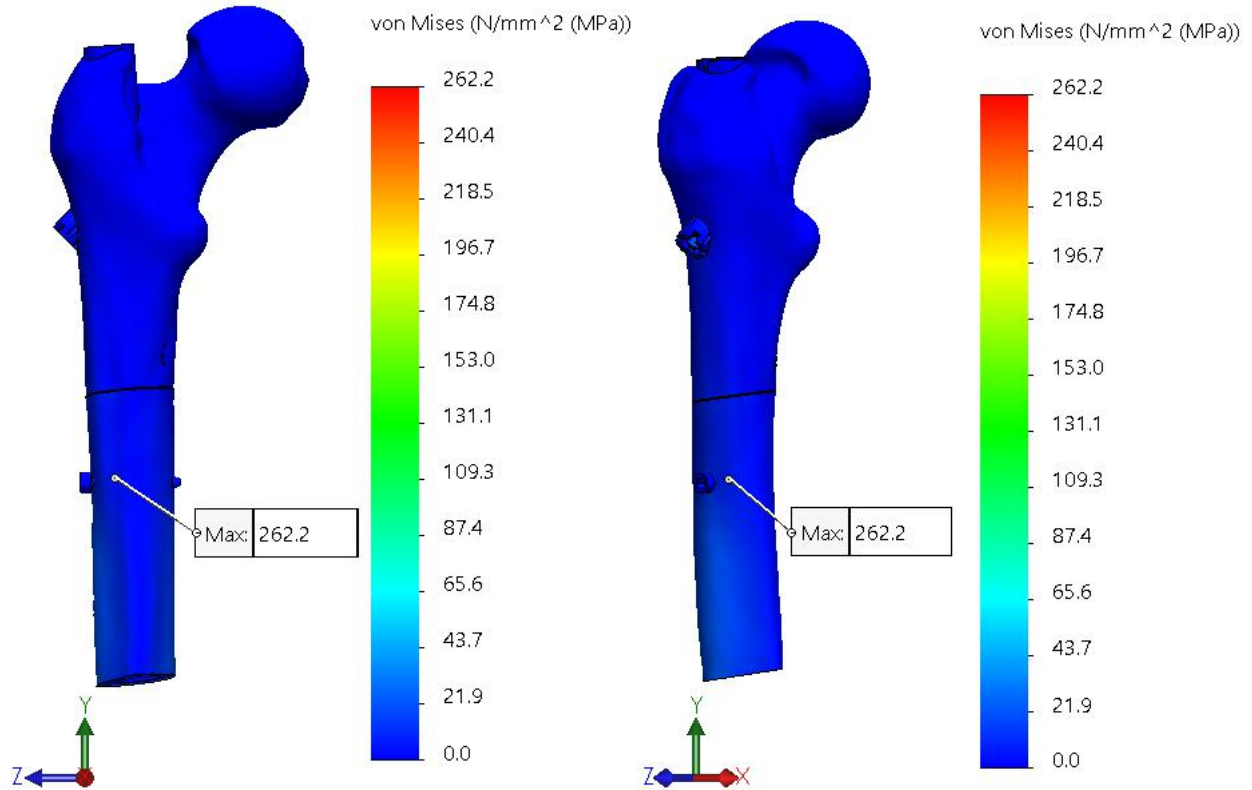

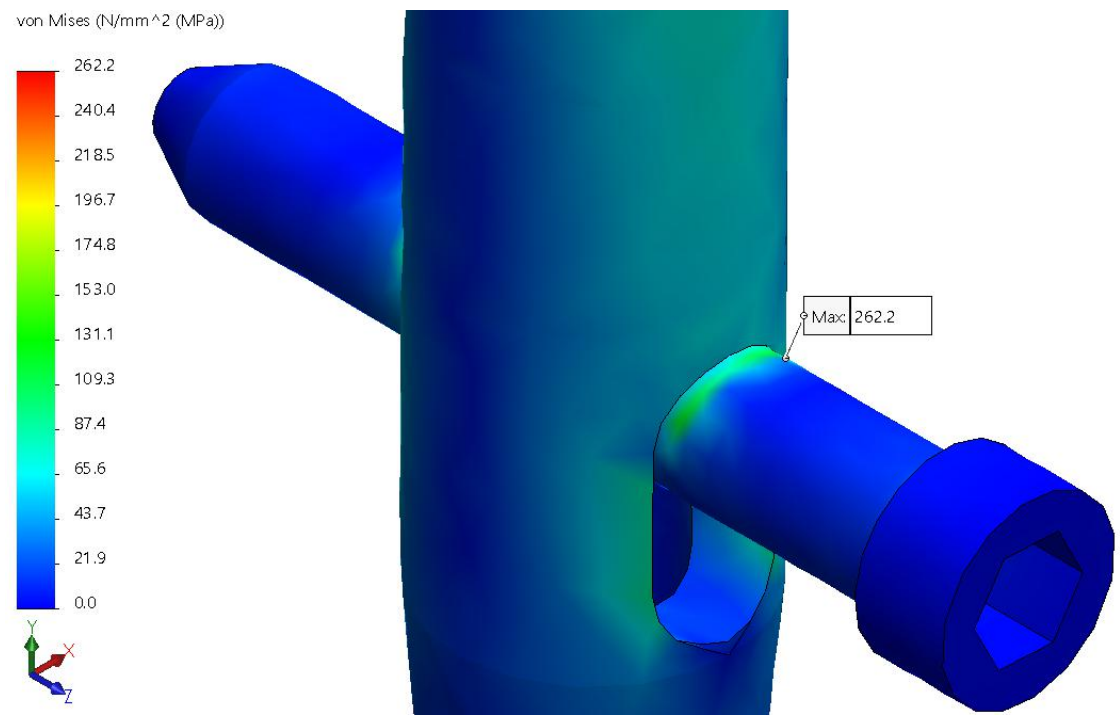
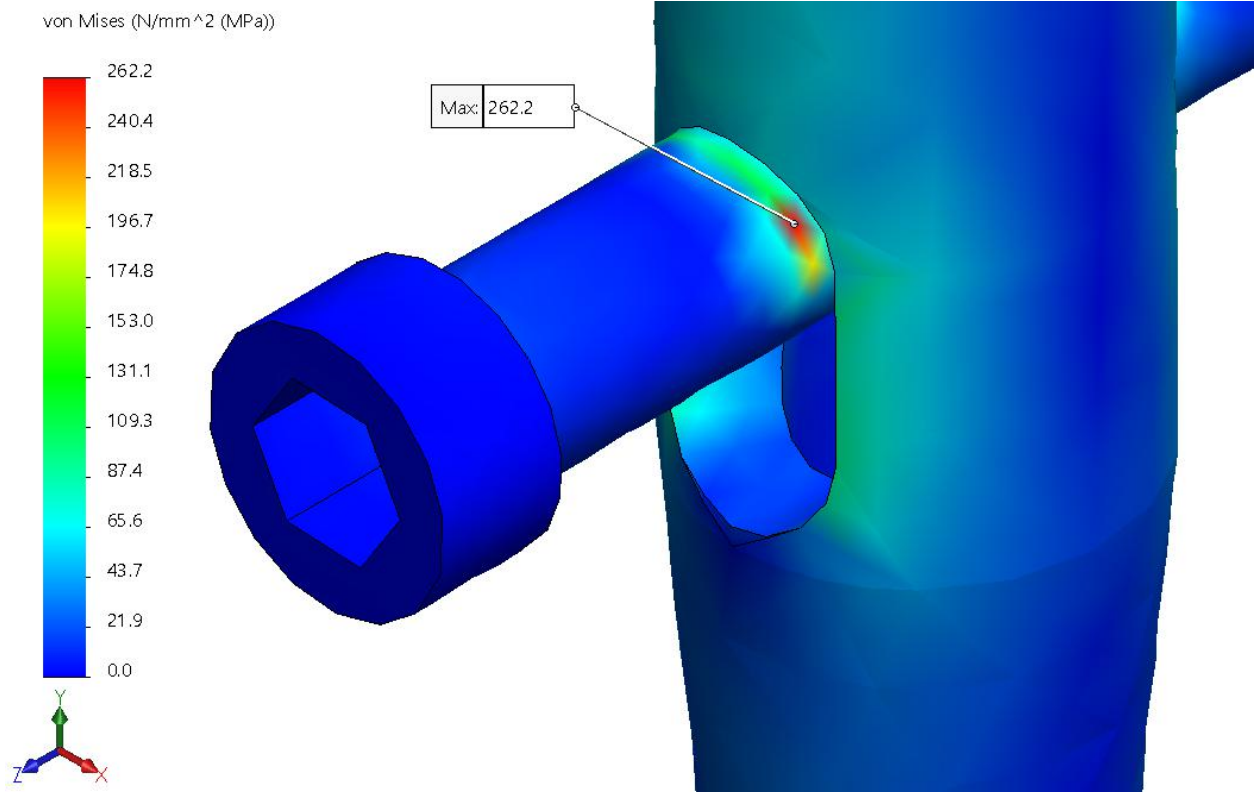

PFNA (location 9: 4.5 cm below LT)

Force: 125 N

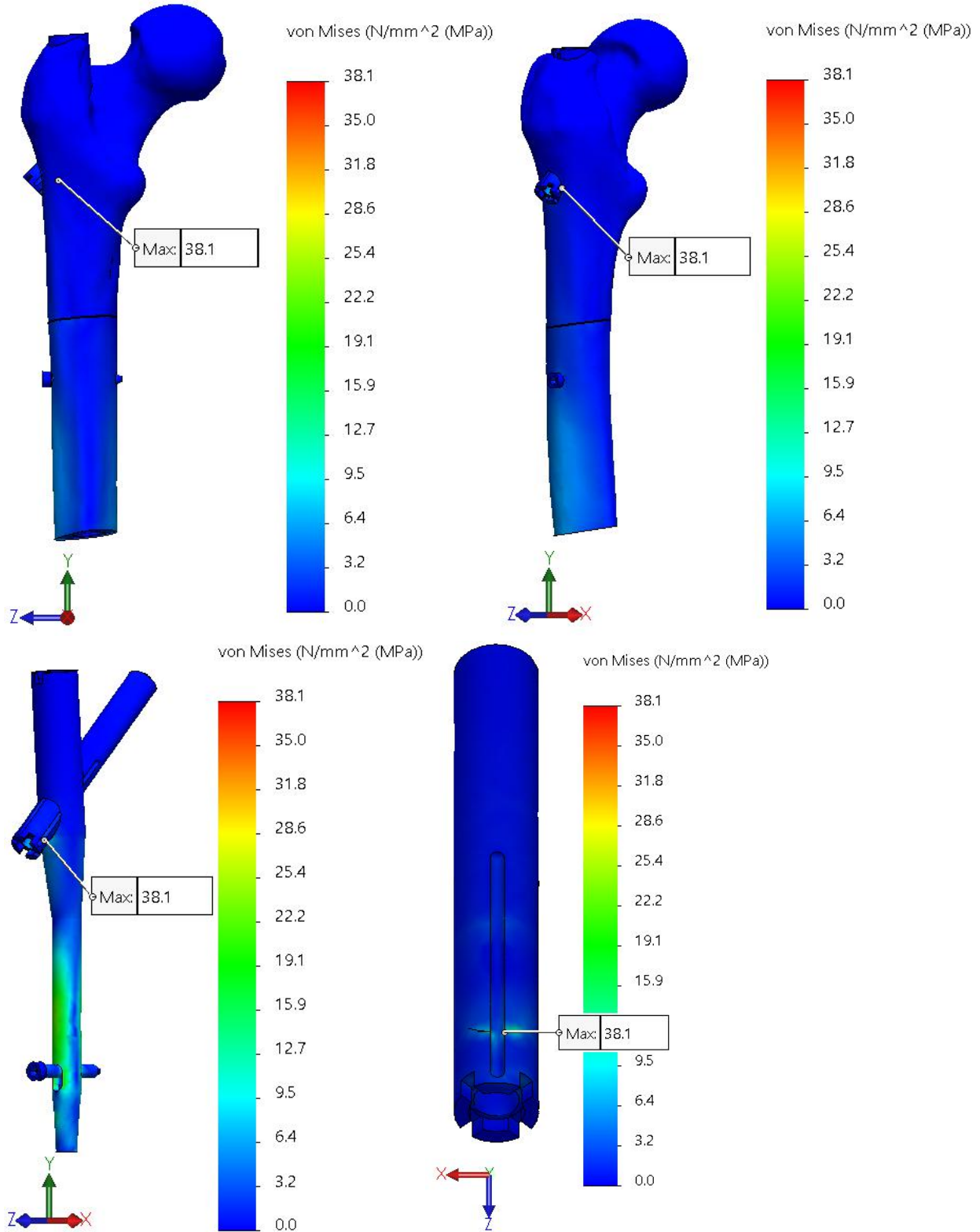

Force: 250 N

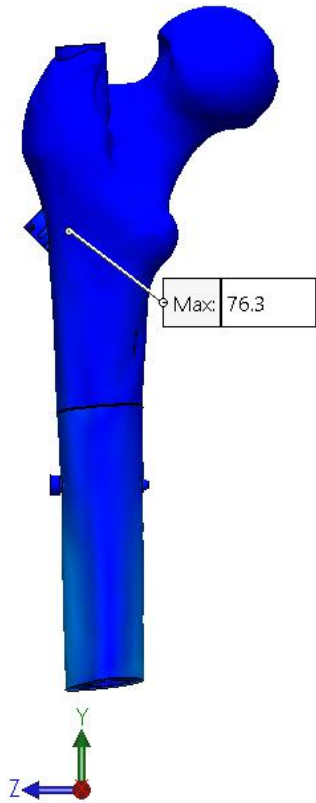

von Mises (N/mm² (MPa))

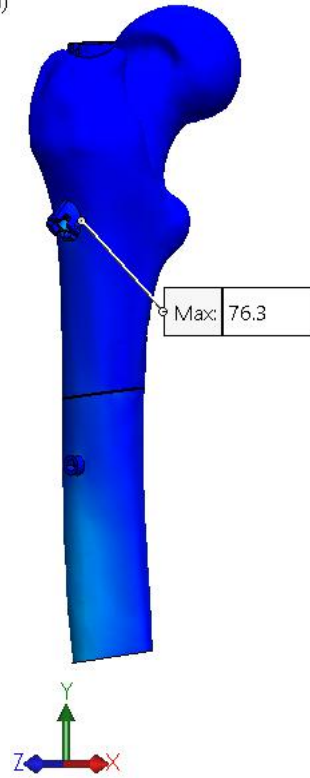
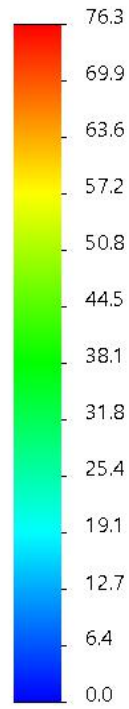

von Mises (N/mm² (MPa))

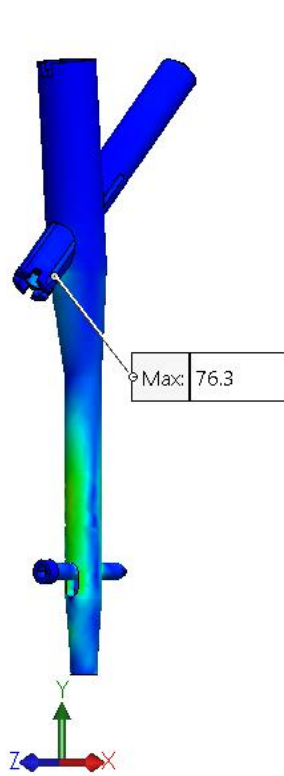
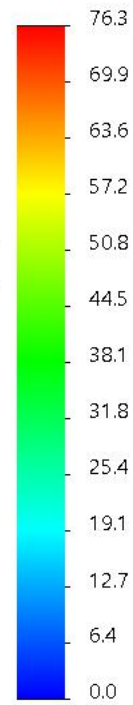

von Mises (N/mm² (MPa))

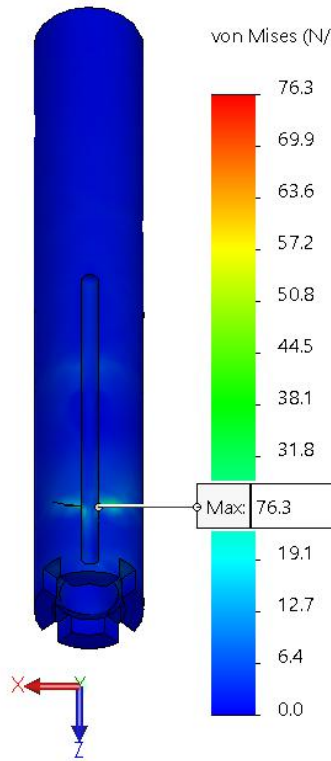
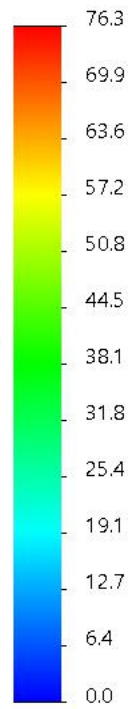

von Mises (N/mm² (MPa))

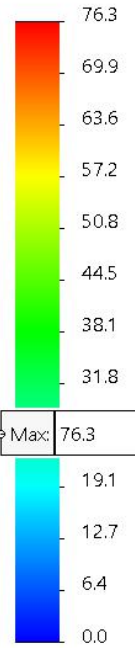

Force: 375 N

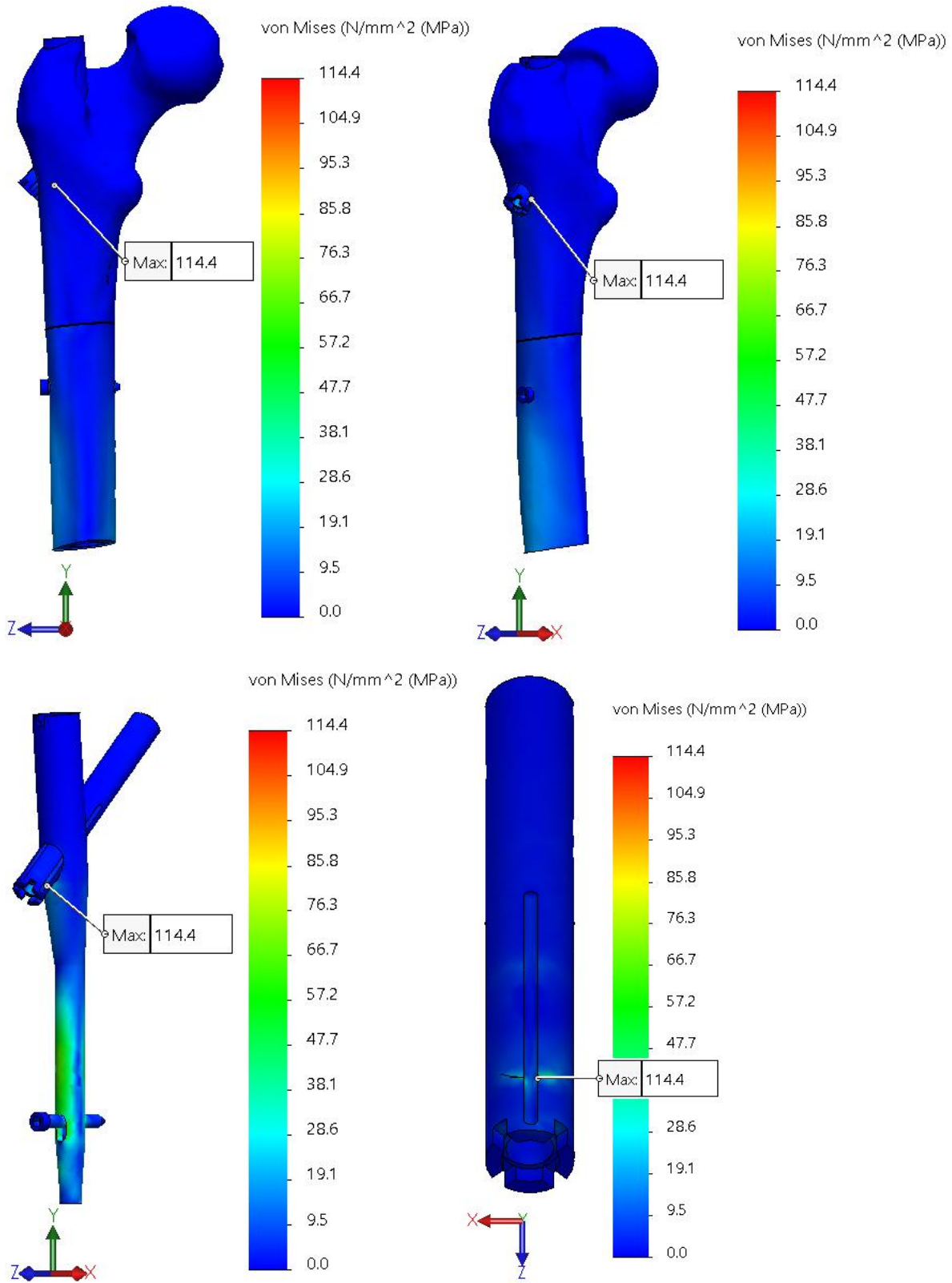

Force: 500 N

